



Series PVP Variable Volume Piston Pumps

*Catalog HY28-2662-CD/US
Revised June, 2012*



**Series Sizes 60 - 140
Phased Out
For Reference Only
Please see P1/PD Series**

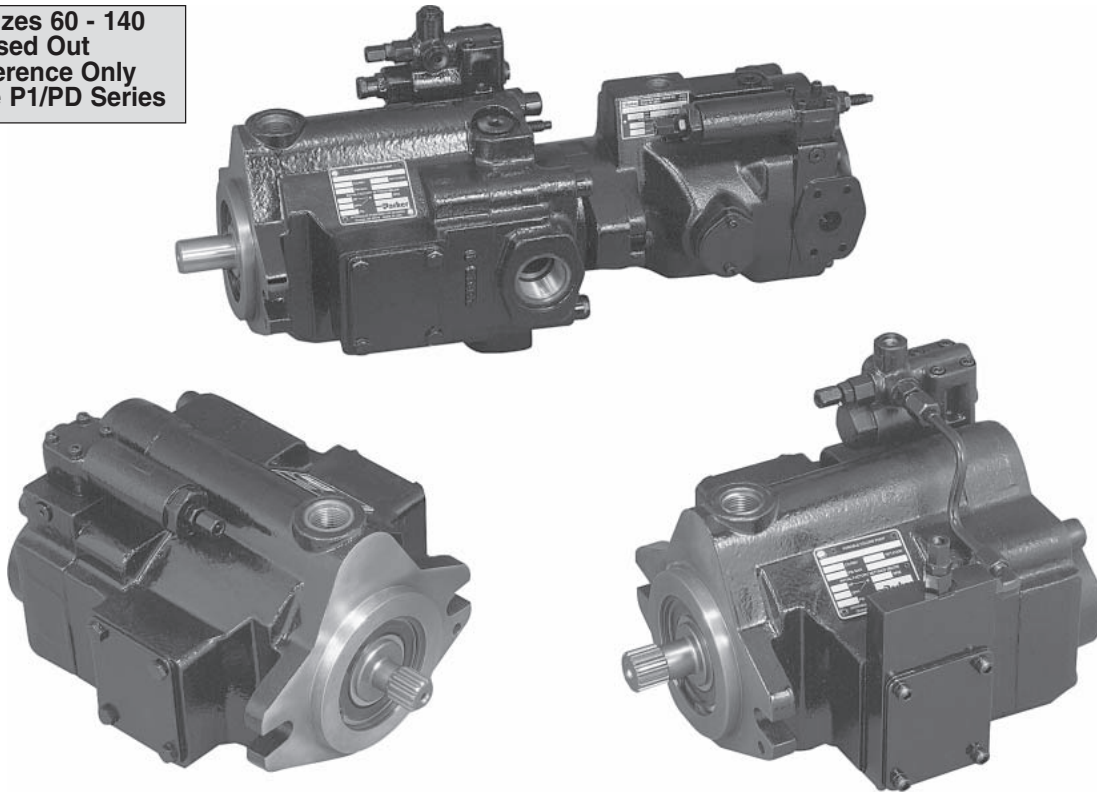

Quick Reference Data Chart

Pump Model	Displacement cc/rev (In ³ /rev)	Pump Delivery @ 21 bar (300 PSI) in LPM (GPM)		† Approx. Noise Levels dB(A) @ Full Flow 1800 RPM (1200 RPM)					Input Power At 1800 RPM, Max. Displacement & 248 bar (3600 PSI)	Operating Speed (RPM) (Maximum)	Pressure bar (PSI) Continuous (Maximum)
				34 bar (500 PSI)	69 bar (1000 PSI)	138 bar (2000 PSI)	207 bar (3000 PSI)	248 bar (3600 PSI)			
		1200 RPM	1800 RPM								
PVP16	16 (.98)	19.7 (5.2)	29.5 (7.8)	53 (47)	55 (50)	59 (54)	62 (56)	65 (59)	13.1 kw (17.5 hp)	3000	248 (3600)
PVP23	23 (1.4)	28.0 (7.4)	42.0 (11.1)	61 (57)	64 (59)	67 (63)	69 (65)	70 (65)	19.7 kw (26.5 hp)	3000	248 (3600)
PVP33	33 (2.0)	39.4 (10.4)	59.0 (15.6)	64 (59)	66 (59)	68 (62)	70 (64)	71 (65)	27.2 kw (36.5 hp)	3000	248 (3600)
PVP41	41 (2.5)	49.2 (13.0)	73.8 (19.5)	68 (60)	70 (61)	73 (65)	74 (67)	75 (69)	33.2 kw (44.5 hp)	2800	248 (3600)
PVP48	48 (2.9)	57.6 (15.2)	86.4 (22.8)	69 (60)	71 (62)	73 (65)	75 (68)	76 (69)	40.3 kw (54.0 hp)	2400	248 (3600)

† Measured in an anechoic chamber to DIN 45635, measuring error ± 2 dB(A).
Fluid used: petroleum oil to ISO VG 46; temperature = 50°C (122°F).

Since many variables such as mounting, tank style, plant layout, etc., effect noise levels, it cannot be assumed that the above readings will be equal to those in the field. The above values are for guidance in selecting the proper pump.

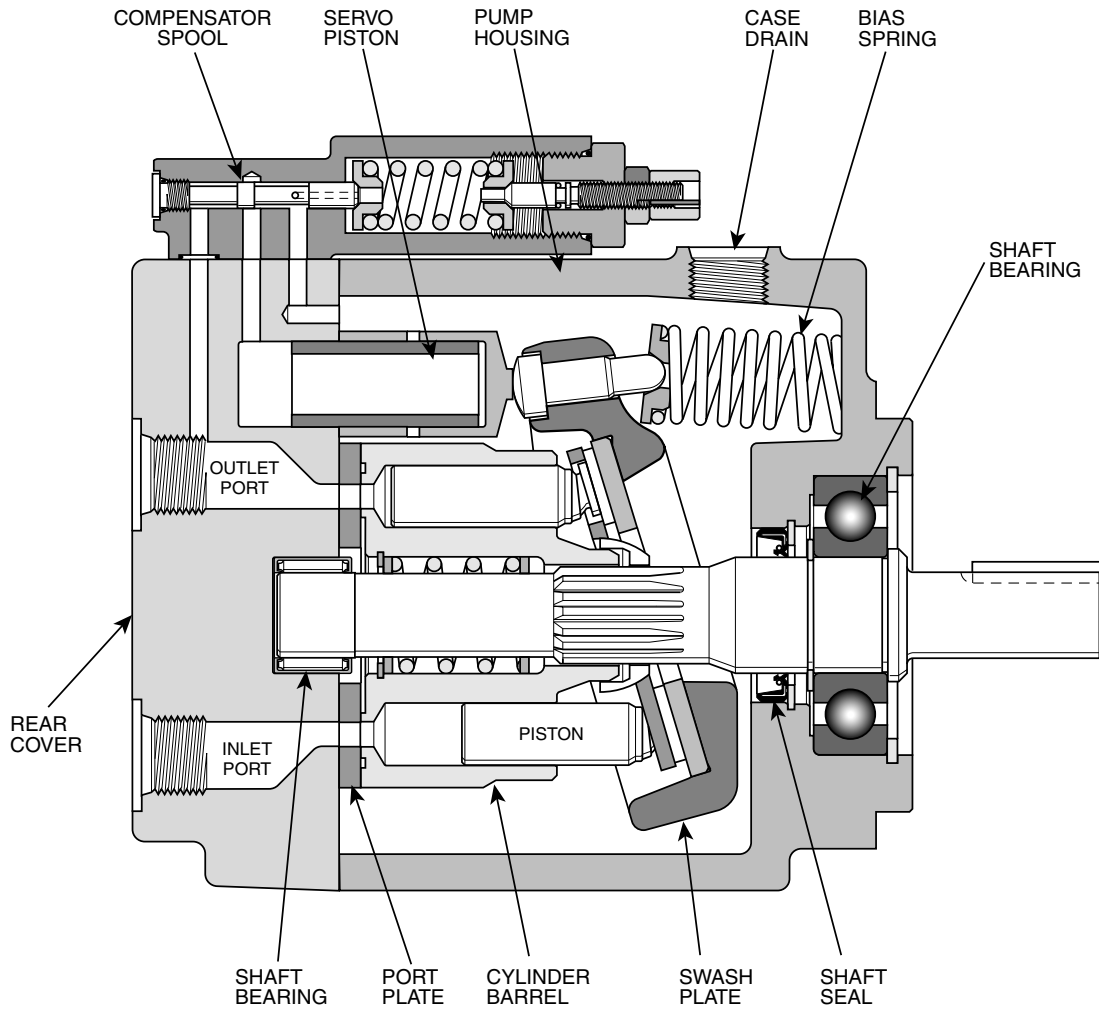

Features

- High Strength Cast-Iron Housing
- Fast Response Times
- Two Piece Housing For Ease of Service
- Metric Pilot, Shaft and Ports Available
- Replaceable Bronze Clad Port Plate
- Thru-Shaft Capability
- Low Noise Levels
- Replaceable Piston Slipper Plate

Controls

- Pressure Compensation
- Load Sensing
- Horsepower Limiting
- Horsepower and Load Sensing
- Remote Pressure Compensation
- Adjustable Maximum Volume Stop
- Hi/Lo Torque (Power) Limiting (PVP 41/48, 60/76, 100/140 Only)
- Low Pressure Standby

General Description

All control is achieved by the proper positioning of the swash plate. This is achieved by a servo piston acting on one end of the swash plate working against the combined effect of the off-setting forces of the pistons and centering spring on the other end. The control spool acts as a metering valve which varies the pressure behind the servo piston.

As shown in Figure 1, the amount of flow produced by the Parker Piston Pump is dependent upon the length of stroke of the pumping pistons. This length of stroke, in turn, is determined by the position of the swash plate. Maximum flow is achieved at an angle of 15-17

degrees. The rotating barrel, driven by the prime mover, moves the pistons in a circular path and the piston slippers are supported hydrostatically against the face of the swash plate. When the swash plate is in a vertical position, perpendicular to the centerline of the piston barrel, there is no piston stroke and consequently no fluid displacement. When the swash plate is positioned at an angle, the pistons are forced in and out of the barrel and fluid displacement takes place. The greater the angle of the swash plate, the greater the piston stroke.

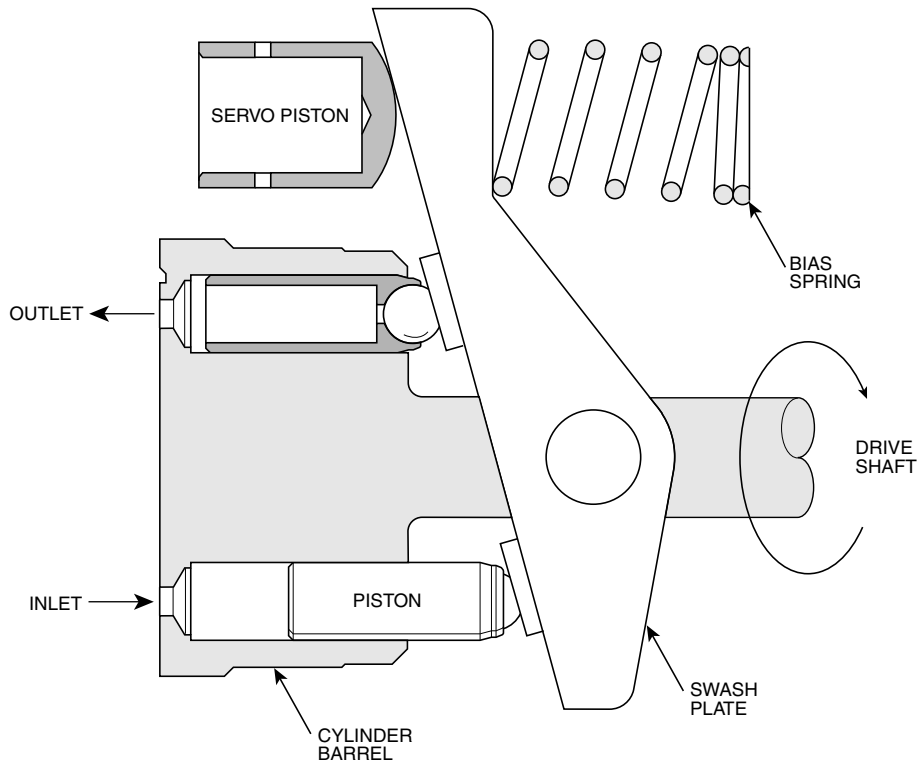

FIGURE 1

Pressure Compensated Control (OMIT)

The swash plate angle controls the output flow of the pump. Swash plate angle is generated by the hydraulic force of the pumping pistons and the mechanical force of the swash plate bias spring.

Control of the pump's outlet flow is obtained by overriding the force of the pumping pistons and bias spring with the hydraulic force of the servo piston by means of internal porting. Pressure is connected from the outlet port to the servo piston via a compensator spool.

The compensator spool is held against the spring guide by the outlet pressure. When the outlet pressure reaches the setting of the compensator control, the compensator spool moves, allowing outlet pressure oil to be metered into the servo piston. This metered oil

provides adequate force to power the servo piston and override swash plate forces. The outlet pressure causes the servo piston to move which reduces the angle of the swash plate and thereby reduces the pump's output flow. When flow is again demanded by the system, the outlet pressure will momentarily fall allowing the compensator spool to move. This movement closes off the outlet pressure to the servo piston and vents the servo piston to case. The result of this venting allows the swash plate forces to move the swash plate angle to maximum displacement, thus responding to the demand for additional flow. Note that the compensator spring chamber is vented to the pump case via a hole internal to the compensator spool.

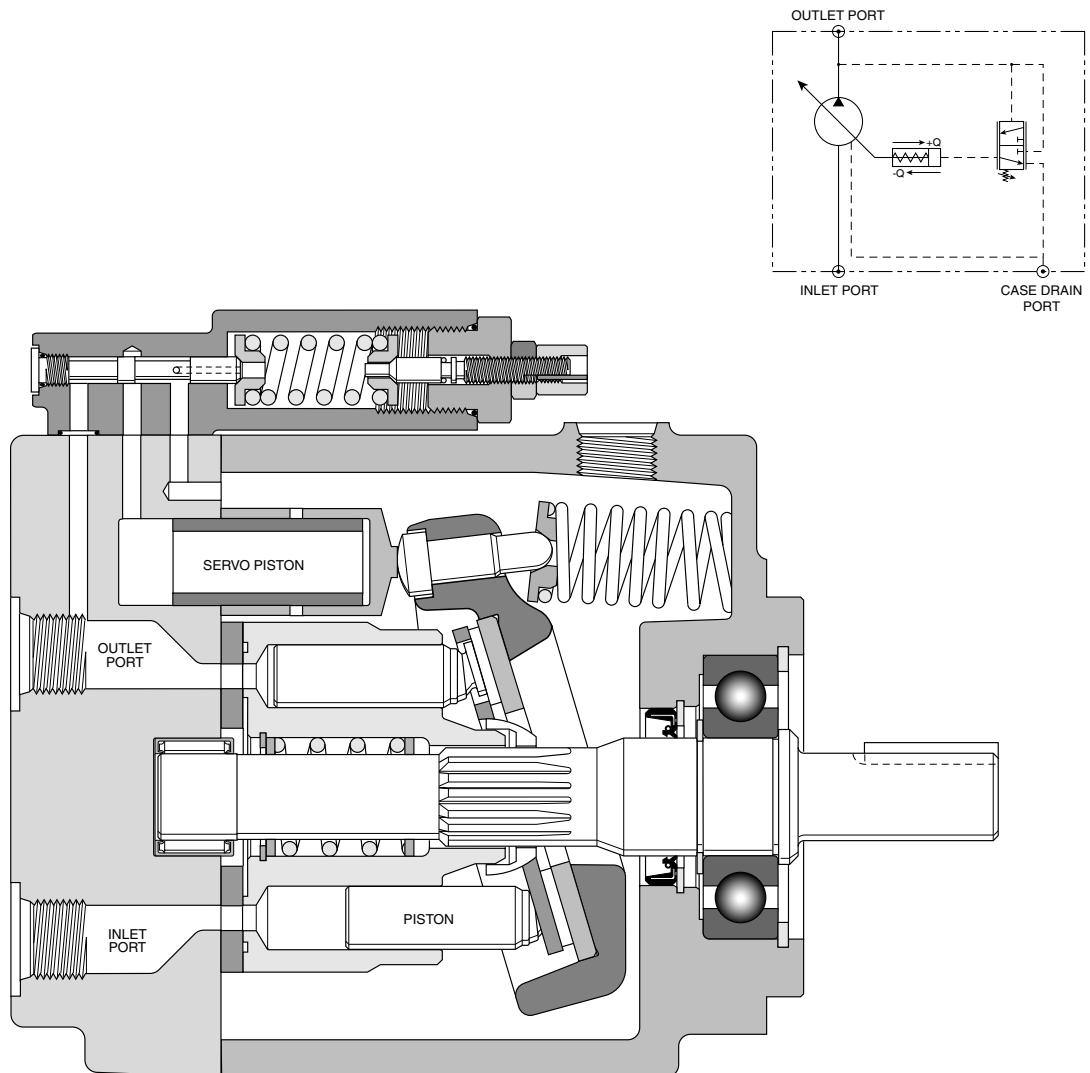

FIGURE 2

Remote Pressure Control (M)

The pump swash plate actuation is identical to the standard pressure compensator but can be controlled via a remote pressure control.

Remote control of the pump output pressure can be achieved by controlling the pressure at port A, Figure 3 on the compensator. Flow is metered through the orifice in the spool from outlet pressure into the spring chamber. The spring chamber pressure is limited by an external relief connected to port A. The controlled pressure at port A is sensed at the differential spring chamber. The compensator spool will move to the right when the pump outlet pressure reaches a force equal to the differential spring setting plus the controlled port

pressure setting. When the spool moves to the right, outlet pressure oil is metered to the servo piston and the pump swash plate angle is controlled accordingly. With this option the pump outlet pressure can be controlled and varied from a remote location.

This control also incorporates a pressure limiting feature preset at the factory. When the pressure in the differential spring chamber reaches the maximum relief setting, the dart unseats allowing the spring chamber to vent to the pump case and limits the maximum pressure attainable.

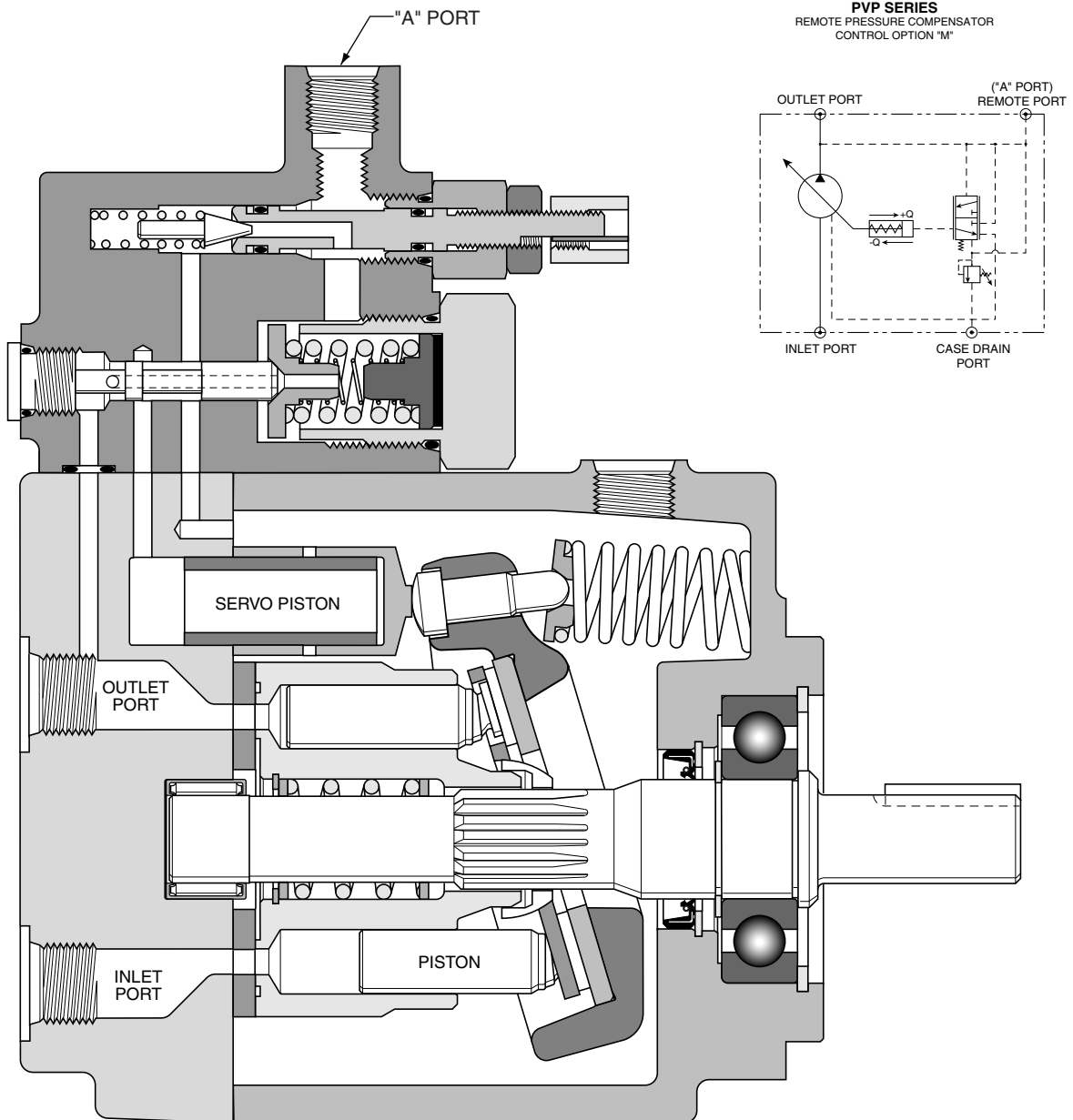

FIGURE 3

Flow Control (Load Sensing) (A)

Figure 4 shows a PVP pump with flow control. The control is identical to the remote pressure compensation control except for an integral orifice, a solid compensator spool and adjustable differential pressure control. Port A is connected downstream of an orifice (variable or fixed) to sense the actual working pressure required. This pressure plus the differential spring force act on the right side of the compensator

spool and will urge the spool to the left until output pressure acting on the left side of the spool balances the forces. As the load increases, output pressure will increase and maintain a constant differential pressure across the orifice and thus a constant flow. Maximum pressure is limited by the internal dart setting. This setting is adjustable up to the maximum preset at the factory.

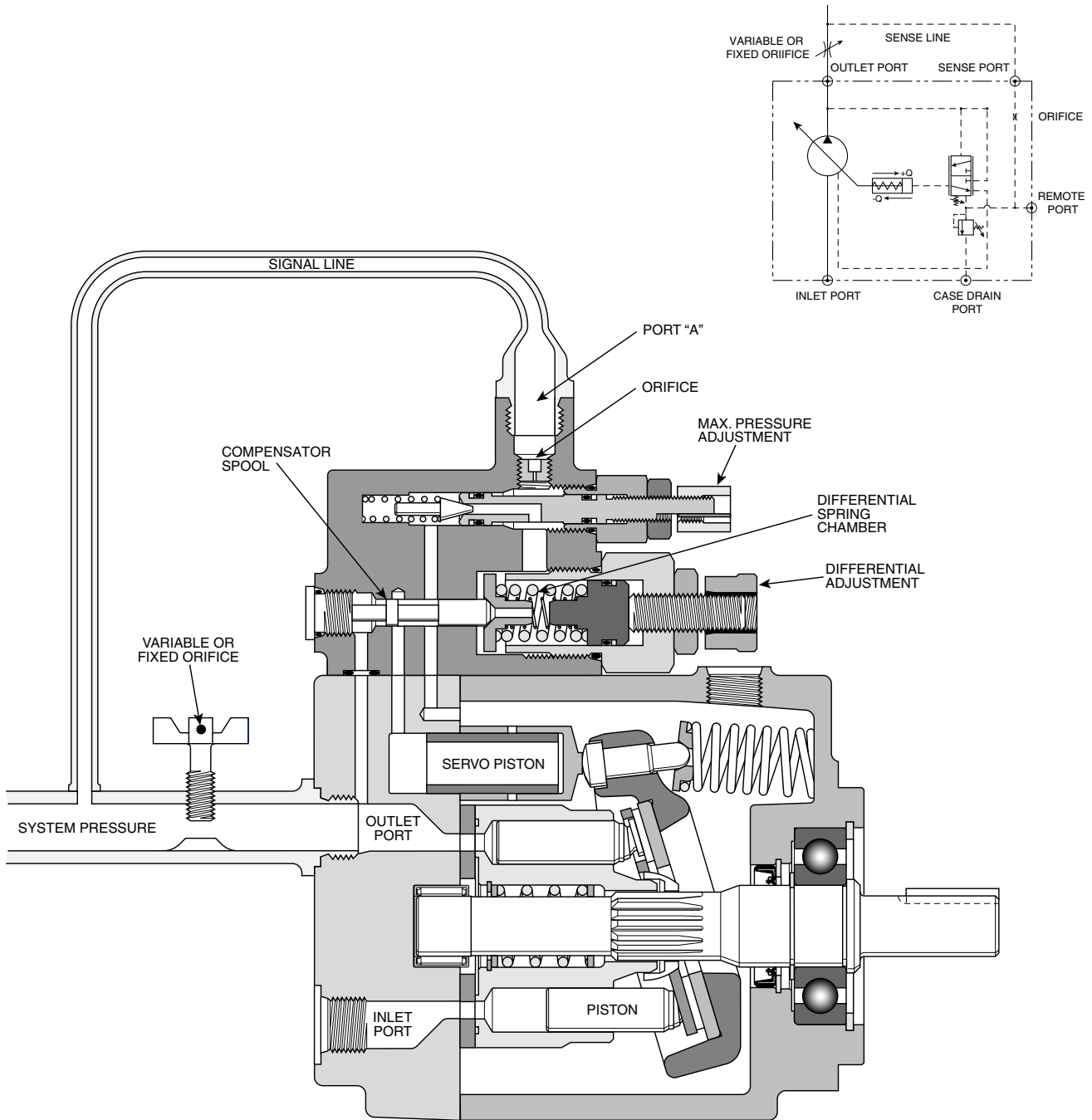

FIGURE 4

Pressure & Power Control (H)

This control option is a Torque Limiting Control, but for constant speed applications it is generally referred to as a Horsepower Control. This control works in conjunction with the Remote Pressure Compensator, control option "M". A second pressure control device called a horsepower control block, is assembled to the main pump housing. The HP block is plumbed to one of the ports on the remote compensator via steel tubing. The control dart in the HP block and the maximum pressure compensator dart in the remote compensator are connected in parallel. What makes the control dart in the HP block different from any other external relief valve is the pressure setting is mechanically linked to the pump swashplate angle.

The cracking pressure of the HP dart is generally lower than the cracking pressure of the remote compensator dart. When the HP dart opens the pressure in the

differential spring cavity is lowered allowing the compensator spool to meter system pressure in the servo piston. As the servo piston extends, it rotates the washplate and in turn rotates the HP cam. As the cam rotates it increases the force on the HP dart control spring. As the system pressure is allowed to increase, the pump gradually reduces its stroke (flow). When the system pressure reaches the setting of the maximum pressure dart the normal action of the remote compensator takes over. If the HP control is set low enough, the pump may reach zero stroke before the system pressure ever gets a chance to open the maximum compensator dart. This should be considered when making low power settings on systems requiring high working pressures.

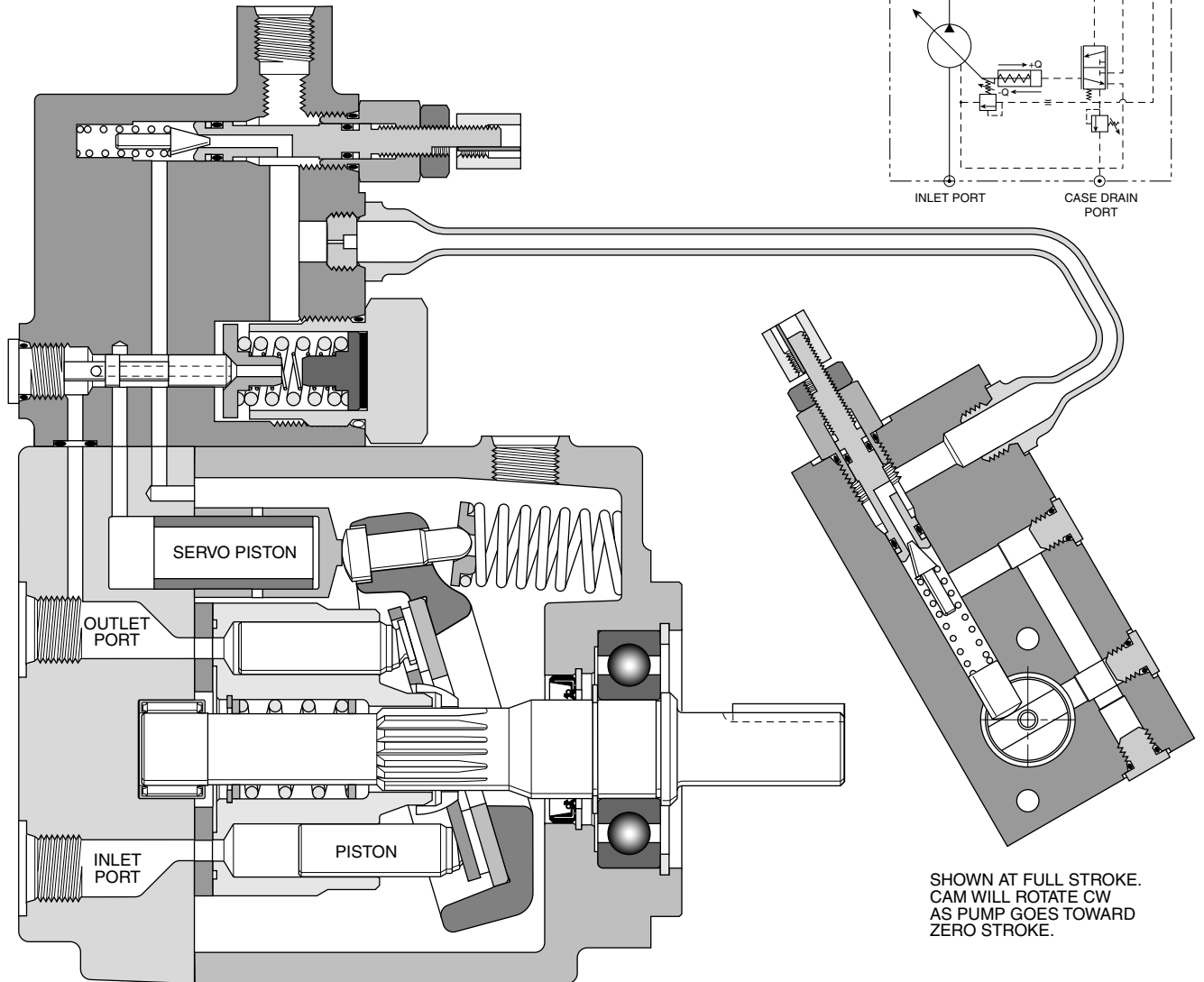

FIGURE 5

Pressure, Power & Flow Control (C)

Refer to the previous section(s) on Flow Control and Power Control. This is another case where multiple controls can be combined in parallel. Since the Power Control is just a special version of Remote Pressure Control, it can be combined with the Flow Control (Load Sense) option. The main point to remember here is that the pressure drop which is required to begin and maintain compensation comes from an external device (such as a proportional valve). This sensed pressure drop will control flow until one of the limits of the other controls has been exceeded. The pump will always respond to the lowest control setting for any given pressure. In addition to Load Sensing, Power Control,

and on-pump Pressure Control, Remote Pressure Control can also be included in this parallel device package. There is a remote port on the compensator body and one on the HP Control body, either of which may be used for remote pressure control. The important concept to remember in load sense circuits is that each pressure control device in and connected to the compensator must be protected from saturation. For this reason, use only the uppermost port on the compensator for connection of the load sense line and insure that an appropriate orifice is installed. All control options using a load sense compensator spool are supplied with this orifice.

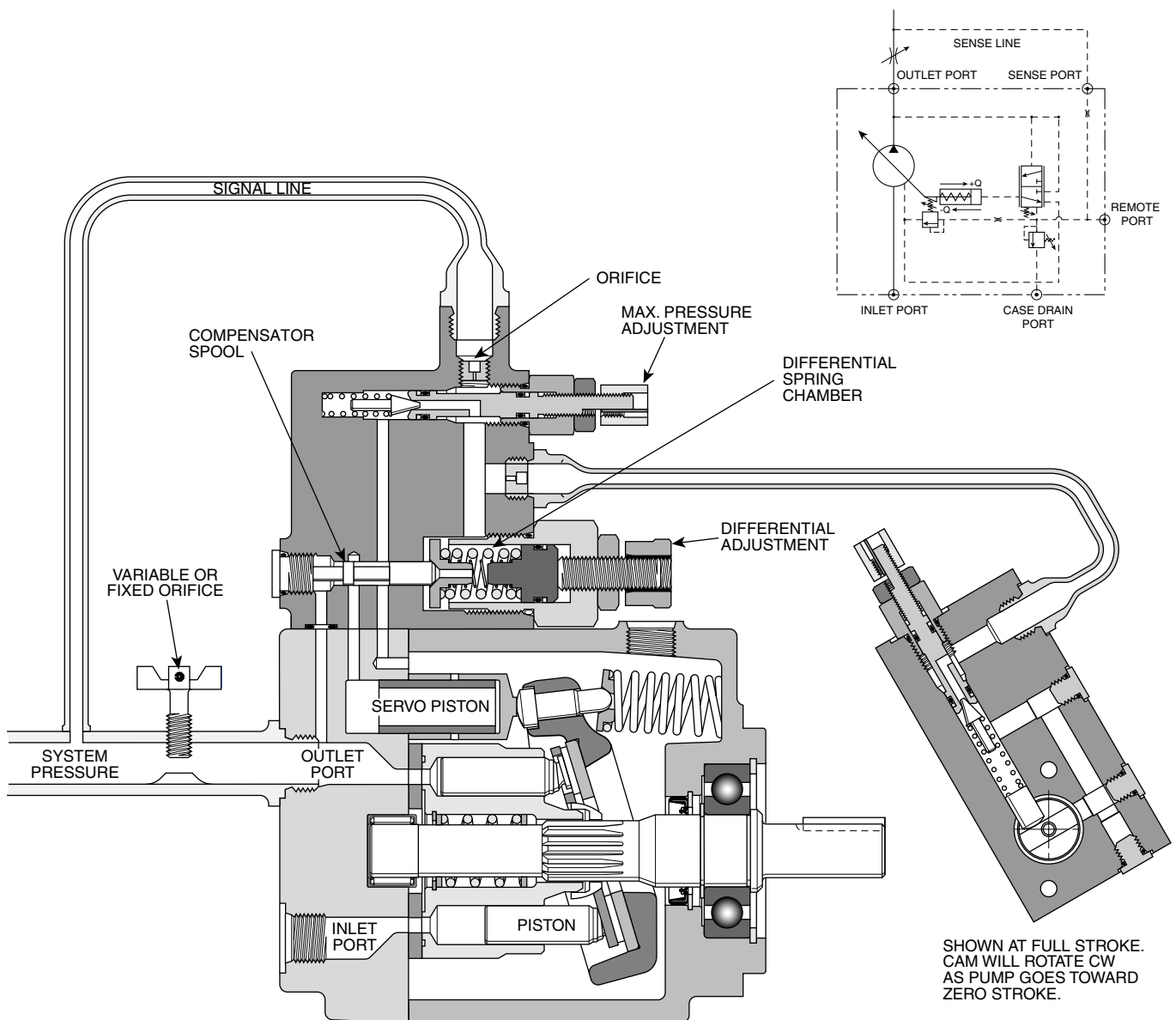

FIGURE 6

hpm102-1.p65, lw, jk

Hi/Lo Power Control (HLM)

(Available with PVP41 and PVP48 Only)

The graph shown below represents the flow-pressure characteristics of a Hi-Lo control for PVP pumps. There are up to four separate adjustments that must be made with the pump controls to get a particular setting, all of which influence the shape of the curve. To get the proper settings, it is very important that all pertinent information is supplied with each Hi-Lo pump ordered. As you can see from the graph below, there are two peak power points. Our intention is to have the same magnitude of power required for both peaks. Of course many combination of settings are possible but specification of the settings becomes very difficult. To make factory settings, we need to know the required **flow** (applicable if pump has a maximum volume stop), the **shaft speed**, the required **Power limit**, and the **compensation pressure**. Based on these requirements, we will adjust the low pressure set point and the reduced flow set point of the Hi-Lo control to best match the requested parameters called out on the order.

Important note: As with power controls, not all combinations of flow, power, pressure, etc. are possible. The first rule is that the settings must conceptually be achievable (i.e. power out is ALWAYS less than power in). Be careful in assuming efficiencies when estimating the Out/In relationship, since a pump operating at low

pressure or in a de-stroked condition can have a much lower overall efficiency than expected. The other thing to keep in mind is that the pump will require the peak power at only two points. All other operating pressures will require less than maximum power and therefore the pump will deliver less hydraulic power in the appropriate ratio based on the actual pump efficiency at those conditions.

**Typical Hi-Lo Control
Flow/Pressure Characteristics**

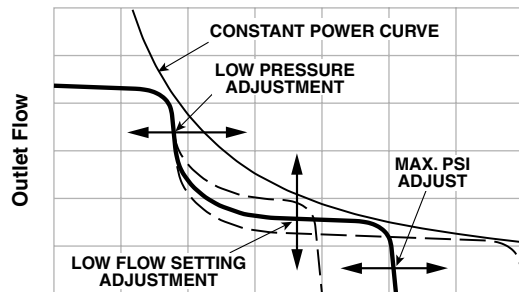

System Pressure

PVP SERIES
PRESSURE & POWER COMPENSATOR
CONTROL OPTION "HLM"

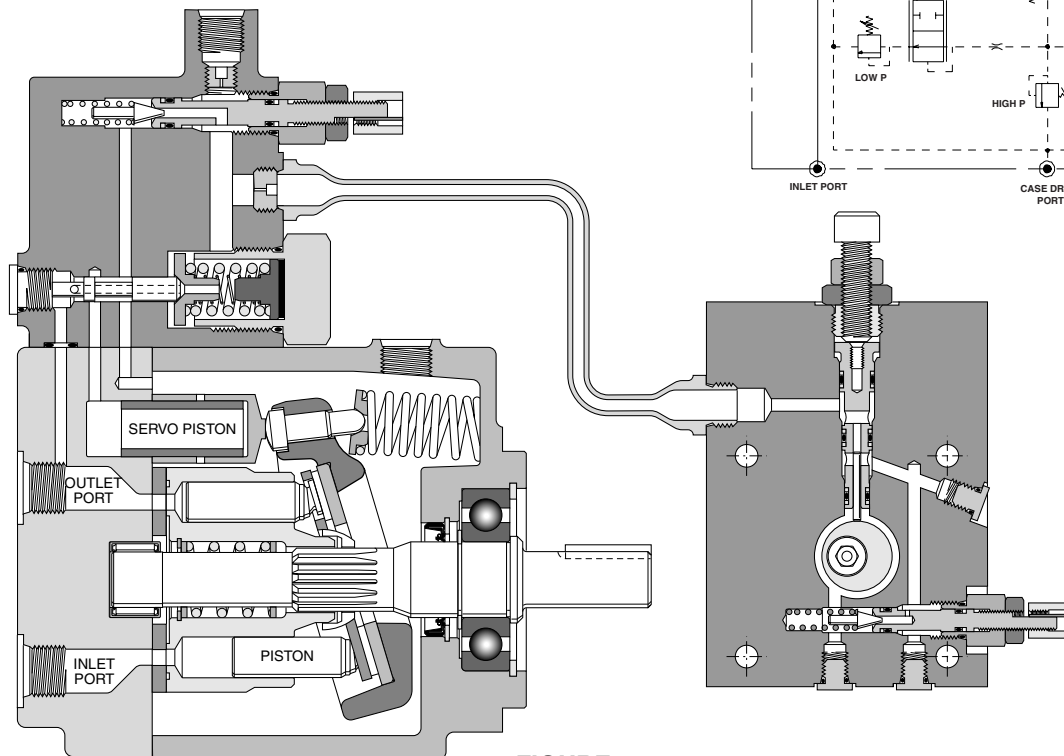
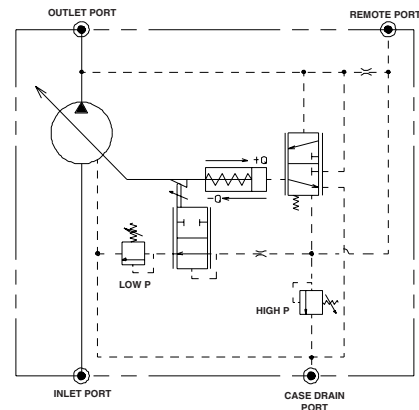

FIGURE 7

hpm102-1.p65, lw, jk

Performance Information

Series PVP16 Pressure Compensated,
 Variable Volume, Piston Pump

Features

- High Strength Cast-Iron Housing for Reliability and Quiet Operation
- Optional Inlet/Outlet Locations for Ease of Installation
- Replaceable Bronze Port Plate
- Replaceable Piston Slipper Plate
- Thru-Shaft Capability SAE A Pilots Offered
- Low Noise Levels - Promote More Comfortable Operating Environment
- Fast Response Times
- Metric Pilot Shaft and Ports Available

Controls

- Pressure Compensation
- Remote Pressure Compensation
- Load Sensing
- Torque (Power) Limiting
- Adjustable Maximum Volume Stop
- Low Pressure Standby

Schematic Symbol

(Basic Pump)

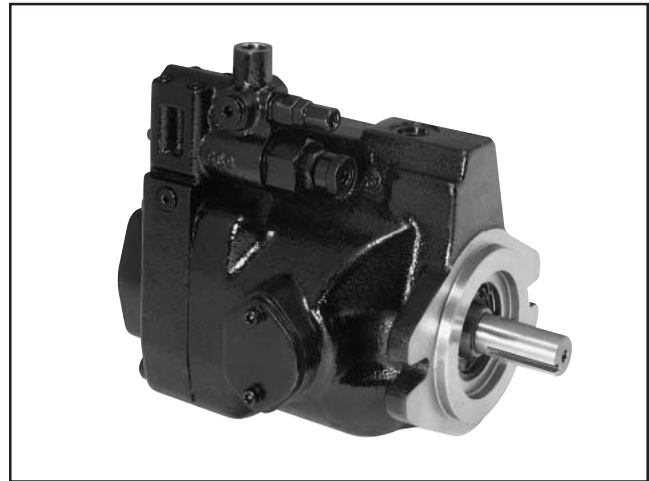
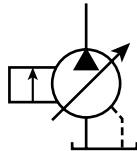

Specifications

Pressure Ratings

Outlet Port: 248 bar (3600 PSI) Continuous (P1)
 310 bar (4500 PSI) Peak (P3)

Inlet Port: 1.72 bar (25 PSI) Maximum
 .17 bar (5 In. Hg.) Vacuum Minimum
 @ 1800 RPM (See inlet chart for other speeds)

Speed Ratings: 600 to 3000 RPM

Operating Temperature Range: -40°C to 71°C
 (-40°F to 160°F)

Housing Material: Cast-Iron

Filtration: Maintain SAE Class 4,
 ISO 16/13,
 ISO 18/15 Maximum

Mounting: SAE "A" or Metric 2-Bolt
 Flange Mount

Installation Data: See page 42 of this catalog for specific recommendations pertaining to system cleanliness, fluids, start-up, inlet conditions, shaft alignment, drain line restrictions and other important factors relative to the proper installation and use of these pumps.

Quick Reference Data Chart

Pump Model	Displacement cc/rev (In ³ /rev)	Pump Delivery @ 21 bar (300 PSI) in LPM (GPM)		† Approx. Noise Levels dB(A) @ Full Flow 1800 RPM (1200 RPM)					Input Power At 1800 RPM, Max. Displacement & 248 bar (3600 PSI)
		1200 RPM	1800 RPM	34 bar	69 bar	138 bar	207 bar	248 bar	
				(500 PSI)	(1000 PSI)	(2000 PSI)	(3000 PSI)	(3600 PSI)	
PVP16	16.4 (1.0)	19.7 (5.2)	29.5 (7.8)	53 (47)	55 (50)	59 (54)	62 (56)	65 (59)	13.1 kw (17.5 hp)

† Measured in an anechoic chamber to DIN 45635, measuring error ± 2 dB(A).
 Fluid used: petroleum oil to ISO VG 46; temperature = 50°C (122°F).

Since many variables such as mounting, tank style, plant layout, etc., effect noise levels, it cannot be assumed that the above readings will be equal to those in the field. The above values are for guidance in selecting the proper pump.

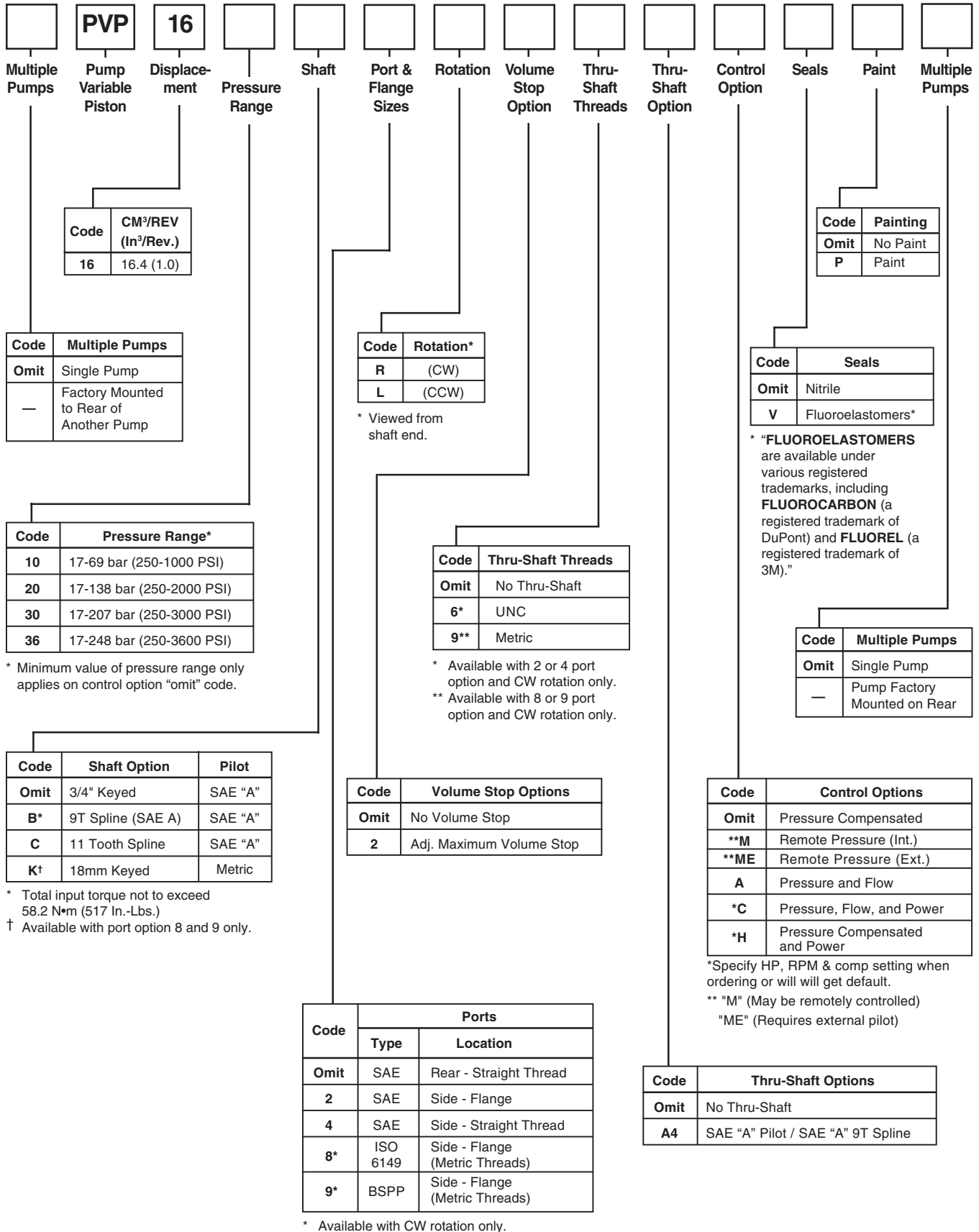

PVP	16
Code	CM ³ /REV (In ³ /Rev.)
16	16.4 (1.0)

Code	Multiple Pumps
Omit	Single Pump
—	Factory Mounted to Rear of Another Pump

Code	Pressure Range*
10	17-69 bar (250-1000 PSI)
20	17-138 bar (250-2000 PSI)
30	17-207 bar (250-3000 PSI)
36	17-248 bar (250-3600 PSI)

* Minimum value of pressure range only applies on control option "omit" code.

Code	Shaft Option	Pilot
Omit	3/4" Keyed	SAE "A"
B*	9T Spline (SAE A)	SAE "A"
C	11 Tooth Spline	SAE "A"
K†	18mm Keyed	Metric

* Total input torque not to exceed 58.2 N•m (517 In.-Lbs.)
 † Available with port option 8 and 9 only.

Code	Rotation*
R	(CW)
L	(CCW)

* Viewed from shaft end.

Code	Thru-Shaft Threads
Omit	No Thru-Shaft
6*	UNC
9**	Metric

* Available with 2 or 4 port option and CW rotation only.
 ** Available with 8 or 9 port option and CW rotation only.

Code	Volume Stop Options
Omit	No Volume Stop
2	Adj. Maximum Volume Stop

Code	Ports	
	Type	Location
Omit	SAE	Rear - Straight Thread
2	SAE	Side - Flange
4	SAE	Side - Straight Thread
8*	ISO 6149	Side - Flange (Metric Threads)
9*	BSPP	Side - Flange (Metric Threads)

* Available with CW rotation only.

Code	Painting
Omit	No Paint
P	Paint

Code	Seals
Omit	Nitrile
V	Fluoroelastomers*

* "FLUOROELASTOMERS are available under various registered trademarks, including FLUOROCARBON (a registered trademark of DuPont) and FLUOREL (a registered trademark of 3M)."

Code	Multiple Pumps
Omit	Single Pump
—	Pump Factory Mounted on Rear

Code	Control Options
Omit	Pressure Compensated
**M	Remote Pressure (Int.)
**ME	Remote Pressure (Ext.)
A	Pressure and Flow
*C	Pressure, Flow, and Power
*H	Pressure Compensated and Power

*Specify HP, RPM & comp setting when ordering or will get default.
 ** "M" (May be remotely controlled)
 "ME" (Requires external pilot)

Code	Thru-Shaft Options
Omit	No Thru-Shaft
A4	SAE "A" Pilot / SAE "A" 9T Spline



Typical Performance Data - Fluid: Standard Hydraulic Oil 100 SSU @ 49°C (120°F)

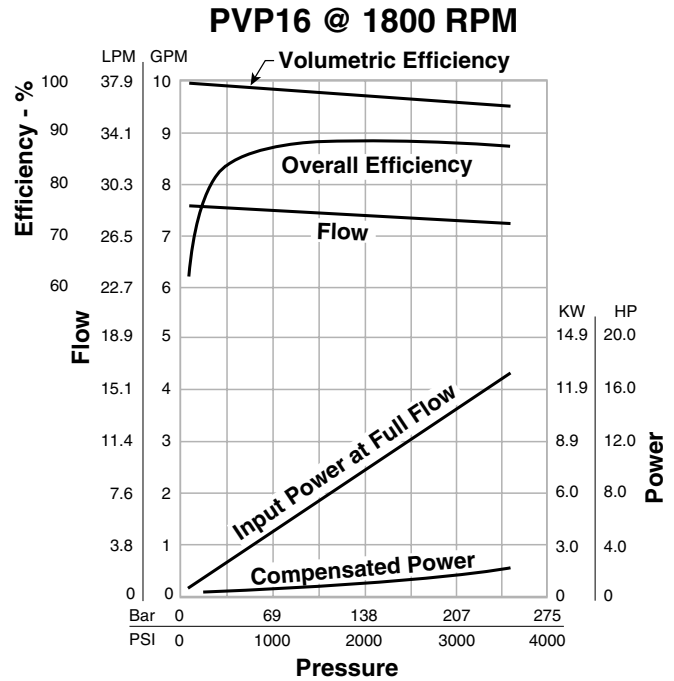
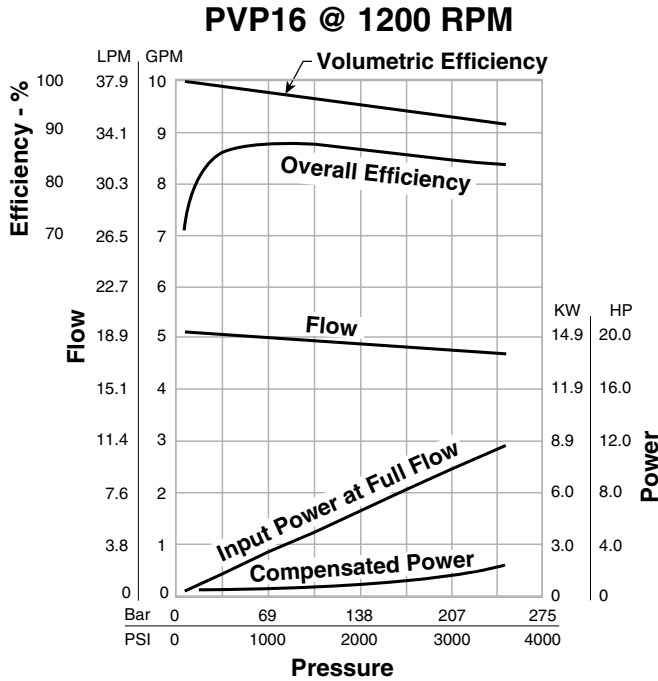

NOTE: The efficiencies and data in the graph are nominal values and good only for pumps running at 1800 RPM and stroked to maximum. To calculate approximate horsepower for the other conditions, use the following formula:

$$HP = \left[\frac{Q \times (PSI)}{1714} \right] + (CHp)$$

Actual GPM is directly proportional to drive speed and maximum volume setting. Flow loss, however, is a function of pressure only.

WHERE:

- Q = Actual Output Flow in GPM
- PSI = Pressure At Pump Outlet
- CHp = Input Horsepower @ Full Compensation @ 1800 RPM
(from graph read at operating pressure)

**PVP16
 Inlet Characteristics at Full Displacement
 (Graph only valid at sea level)**

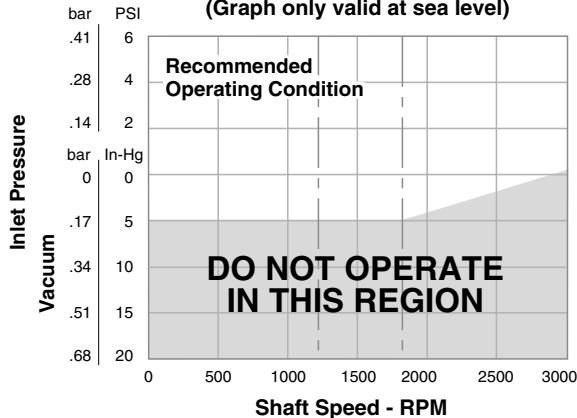

Flow vs. Speed

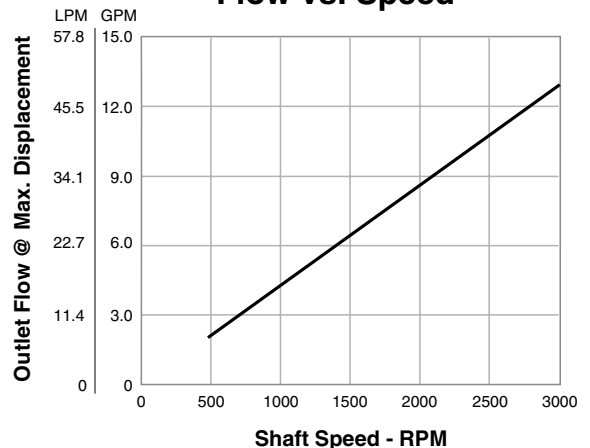

Typical Performance Data - Fluid: Standard Hydraulic Oil 100 SSU @ 49°C (120°F)

Power Control

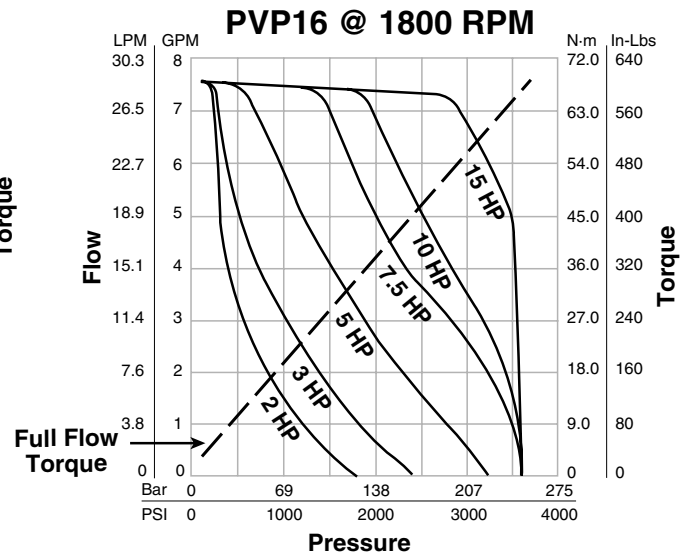
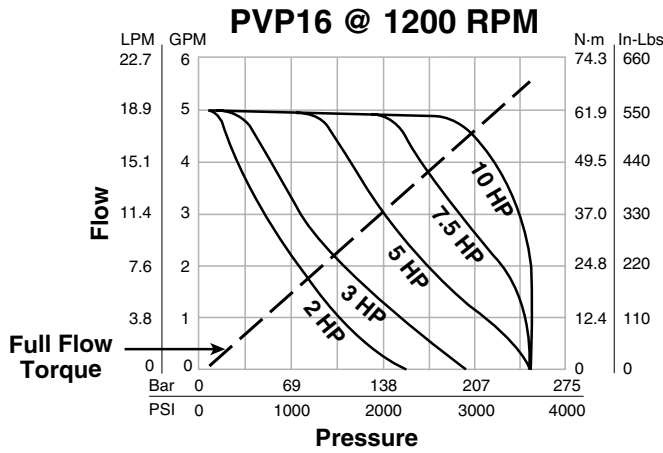

Response Times

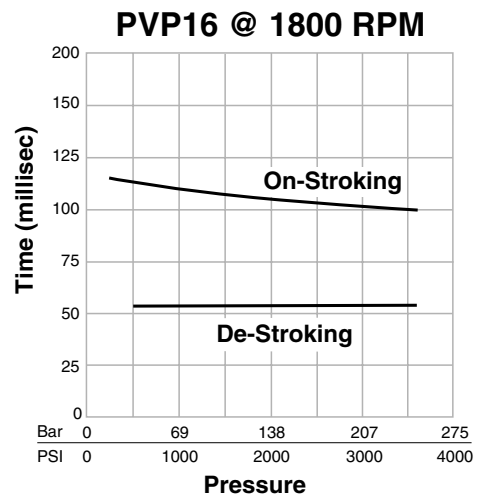
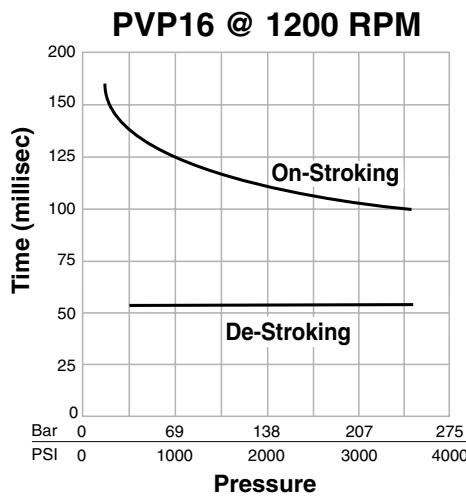

**PVP16
 Approximate Case Drain Flow
 @ 1800 RPM**

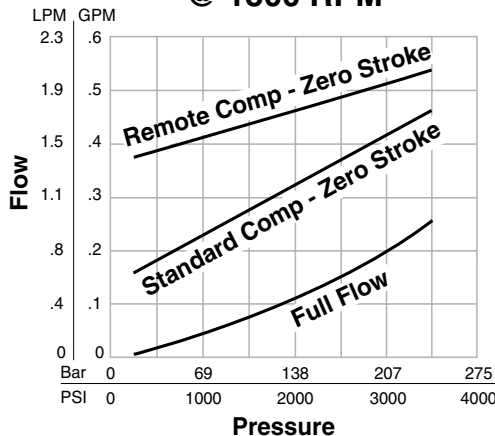

**PVP16
 Compensated Power
 @ 1800 RPM**

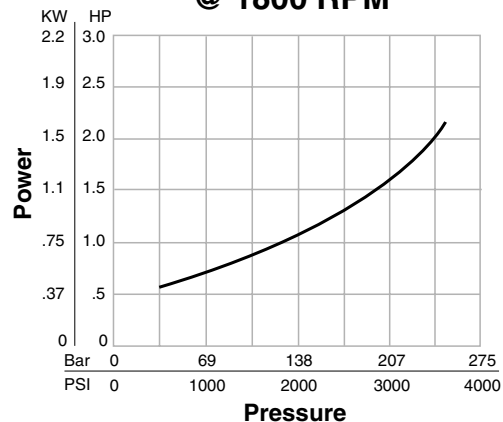

Rear Ported Pump Dimensions

* Inch equivalents for millimeter dimensions are shown in (**).

NOTE:

Illustration shows Righthand (CW) rotation pump. Lefthand (CCW) pumps will have inlet and outlet ports reversed with compensator on outlet side.

Pilot Dimensions			
Pilot Option	A	C	D
OMIT	N/A	32.00 (1.26)	173.23 (6.82)
5	38.10 (1.50)	28.44 (1.12)	144.53 (6.44)

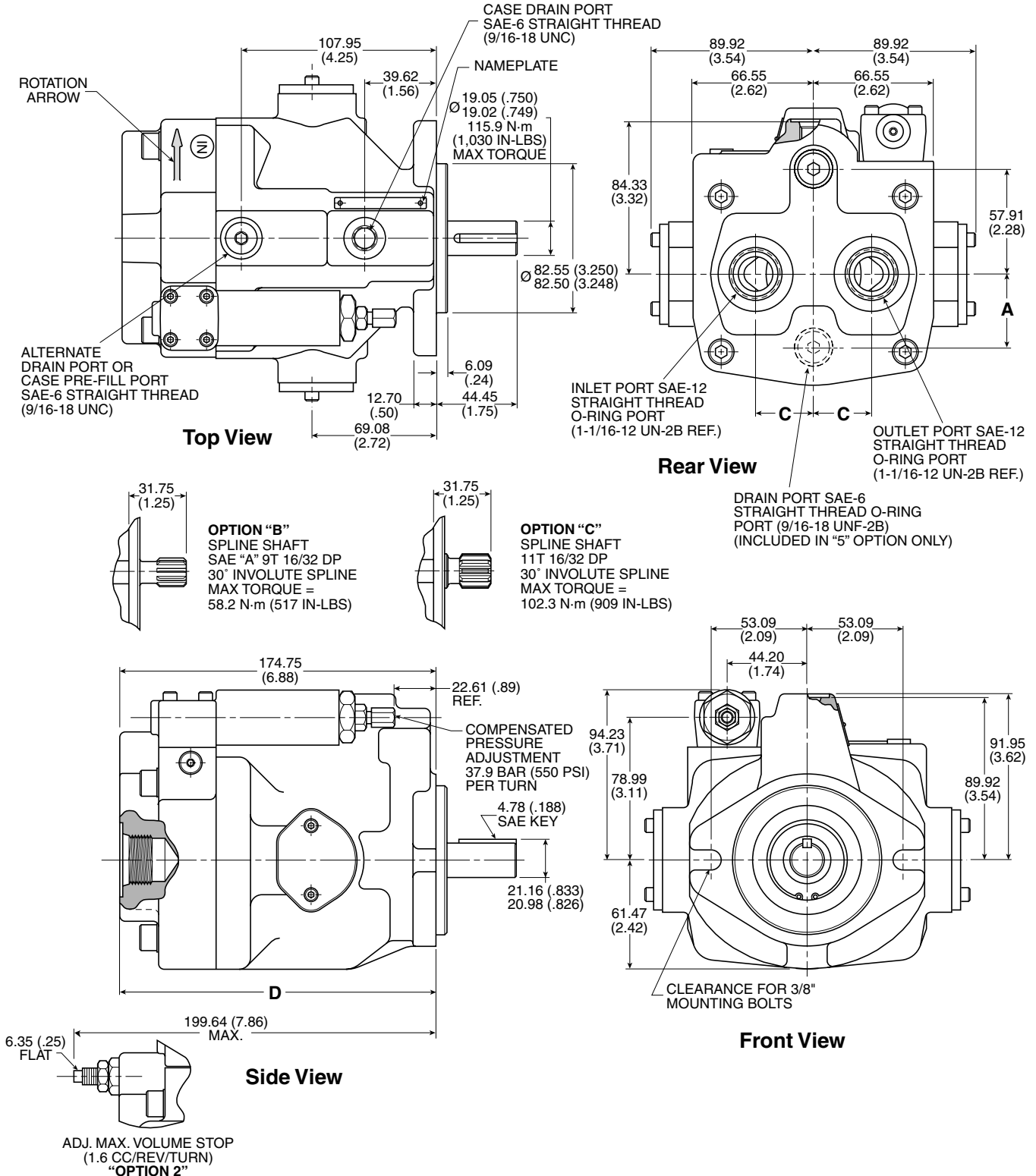

hpm102-1.p65, lw, jk

Side Ported – Options 2 & 4
Dimensions

* Inch equivalents for millimeter dimensions are shown in (**).

NOTE:

Illustration shows Righthand (CW) rotation pump.
 Lefthand (CCW) pumps will have inlet and outlet ports reversed with compensator on outlet side.

Port Size Type and Location			
Option	A	Inlet and Outlet Ports	Drain Port
2	148.84 (5.86)	3/4" SAE 4-Bolt Flange 3/8-16 Thread Std PSI Series (Code 61)	SAE-6 Straight Thread (9/16-18UNC)
4	152.40 (6.00)	SAE-16 Straight Thread (1-5/16-12UN-2B)	SAE-6 Straight Thread (9/16-18UNC)

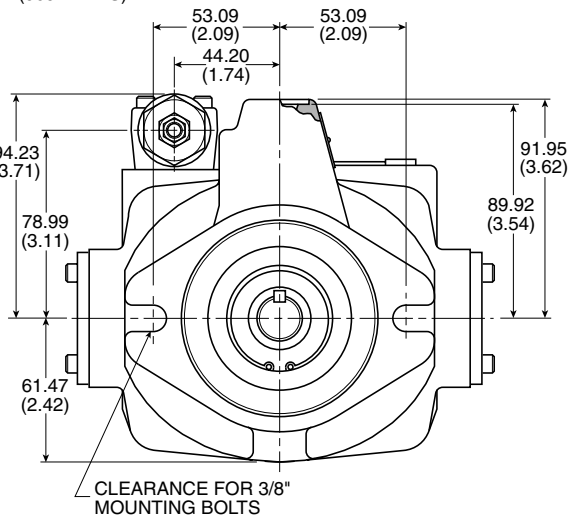
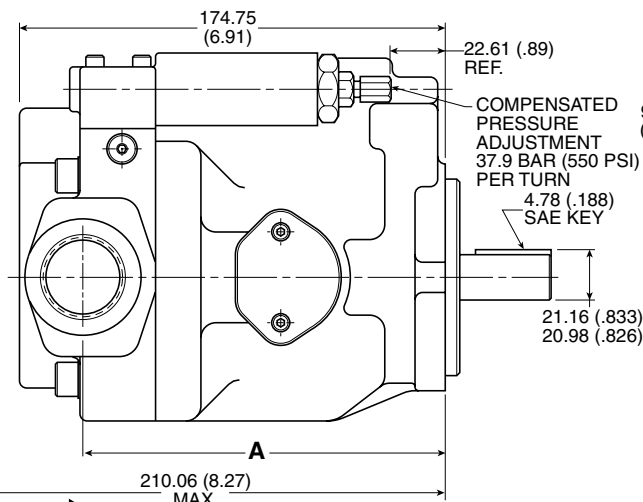
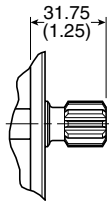
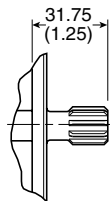
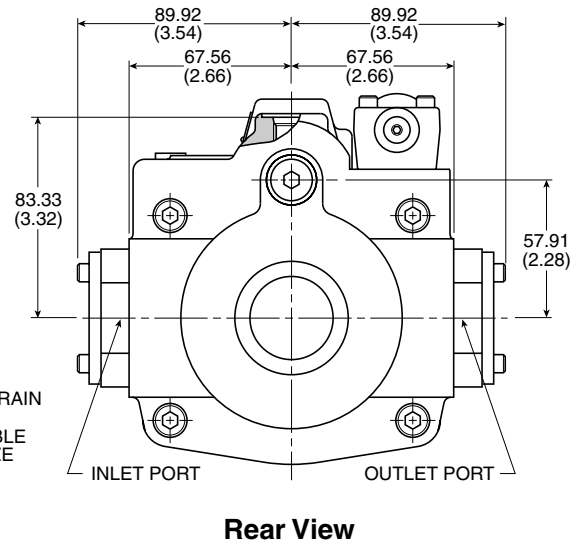
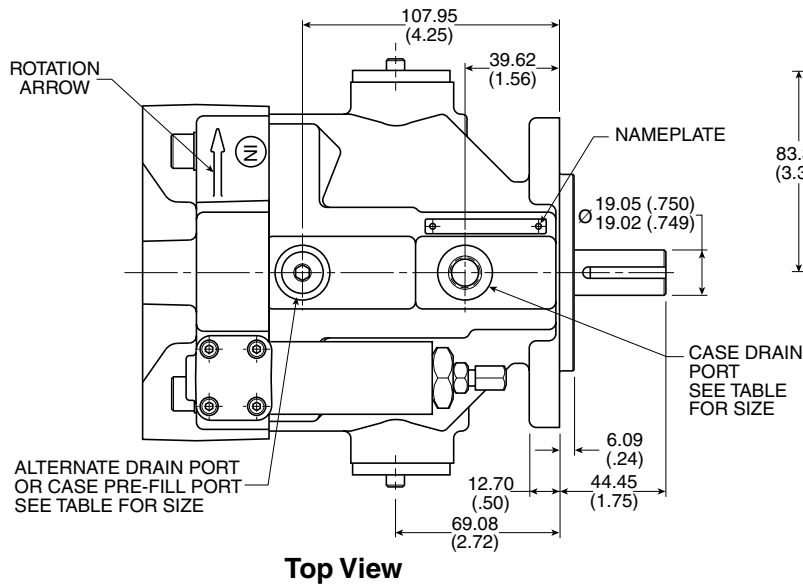

ADJ. MAX. VOLUME STOP
 (1.6 CC/REV/TURN)
 "OPTION 2"

Side Ported – Options 8 & 9 Dimensions

* Inch equivalents for millimeter dimensions are shown in (**).

NOTE:

Illustration shows Righthand (CW) rotation pump.

Shaft Option	Pilot Dimensions			
	A	B	C	D
Omit B, C	82.55/82.50 (3.250/3.248)	6.10 (.24)	53.09 (2.09)	ø 3/8"
K	80.00/79.95 (3.149/3.147)	7.24 (.285)	55.63 (2.19)	ø 10mm

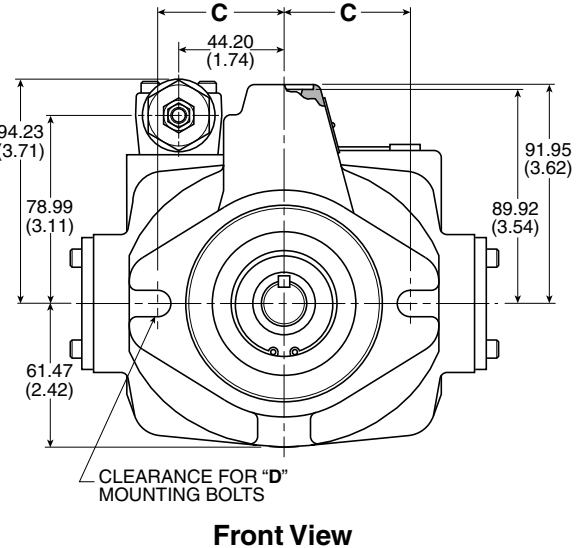
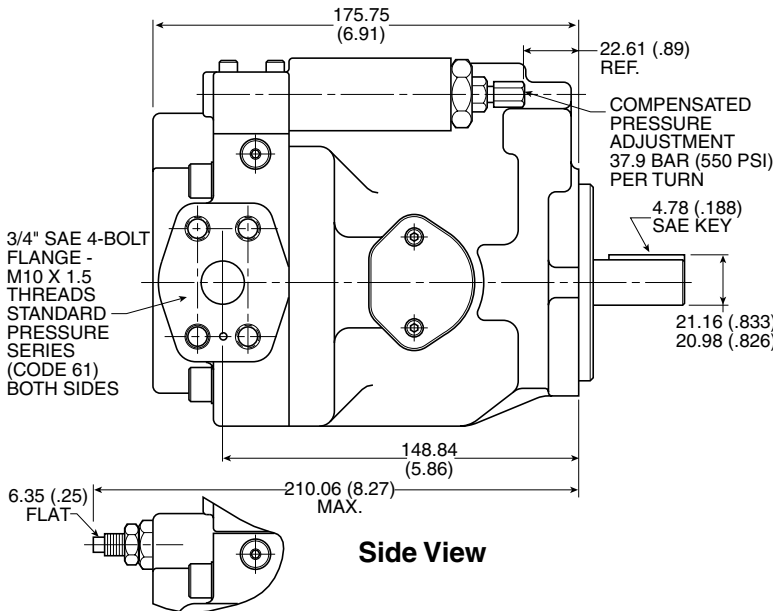
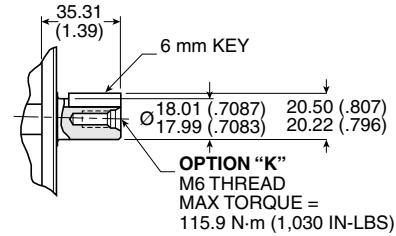
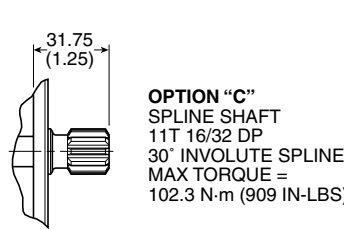
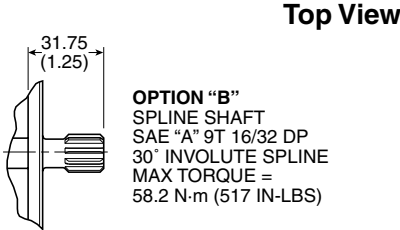
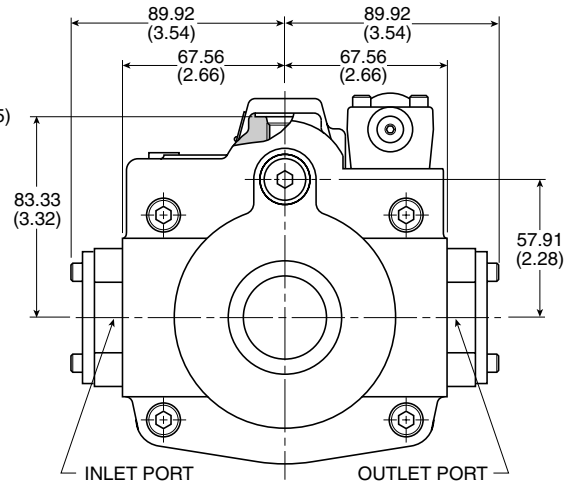
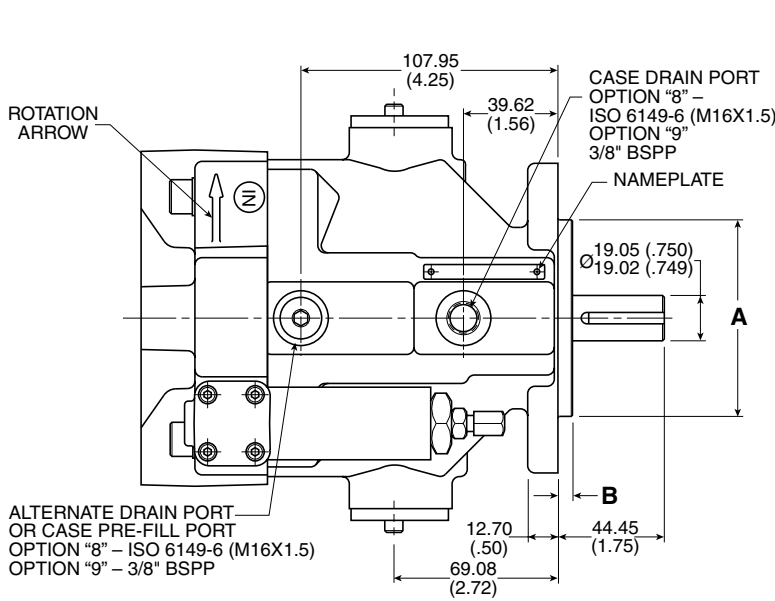

Thru-Shaft Pump Dimensions

* Inch equivalents for millimeter dimensions are shown in (**).

NOTES:

1. Righthand (CW) rotation pump shown above. Counterclockwise (CCW) pump will have inlet and outlet ports reversed with the compensator over the outlet port.
2. Splined shaft (option "B") not recommended with Thru-Shaft pumps.
3. The maximum torque transmitting capacity for rear mounting of pumps is limited by the allowable torque of the input shaft.
4. Options 6A4 and 9A4 Design Series 12 have a gasket. All other options incorporate an o-ring seal and have an o-ring groove.

Port Size Type and Location			
Option	A	Inlet and Outlet Ports	Drain Port
2	148.84 (5.86)	3/4" SAE 4-Bolt Flange 3/8-16 Thread Std PSI Series (Code 61)	SAE-6 Straight Thread (9/16-18UNC)
4	152.40 (6.00)	SAE-16 Straight Thread (1-5/16-12UN-2B)	SAE-6 Straight Thread (9/16-18UNC)
8	148.84 (5.86)	3/4" SAE 4-Bolt Flange M10 Thread Std PSI Series (Code 61)	ISO 6149-6 M16 x 1.50
9	148.84 (5.86)	3/4" SAE 4-Bolt Flange M10 Thread Std PSI Series (Code 61)	3/8" - BSPP

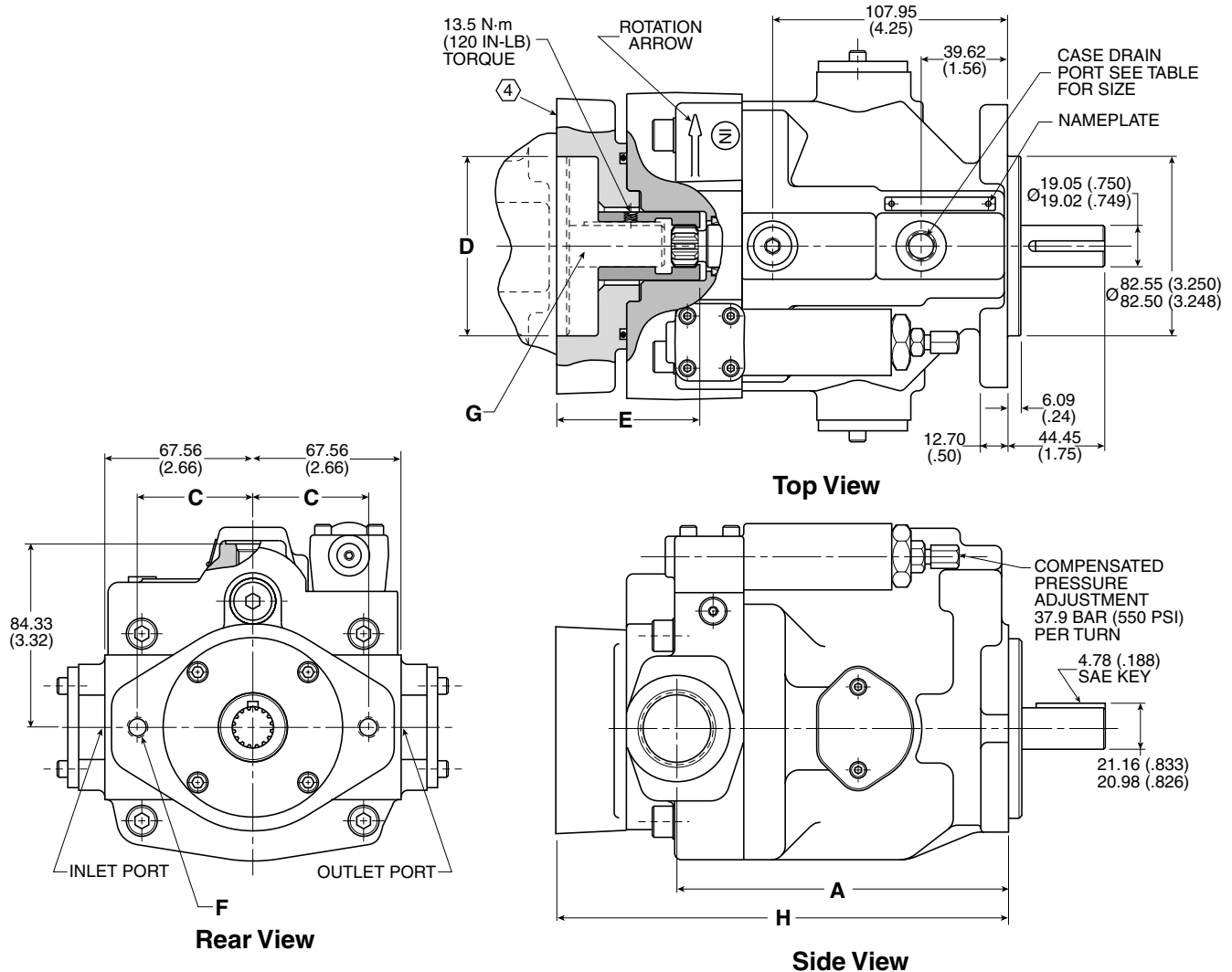

Dimensions – Thru Shaft Options

VARIATION	C	D	E	F	G	H
6A4	53.19 (2.09)	82.58/82.60 (3.251/3.252)	N/A	3/8-16UNC-2B	9 Tooth 16/32 Pitch	207.26 (8.16)
9A4	53.19 (2.09)	82.58/82.60 (3.251/3.252)	N/A	M10 x 1.50	9 Tooth 16/32 Pitch	207.26 (8.16)

Remote Compensator Control Pump Dimensions

* Inch equivalents for millimeter dimensions are shown in (**).

NOTES:

1. Righthand (CW) rotation pump shown below. Lefthand (CCW) pumps will have compensator on opposite side.
2. When controlling pump compensator pressure with remote relief valve, remote relief valve must be capable of passing 1.89 LPM (.5 GPM).
3. Remote compensator option "M", "ME" & "A" available on pumps with any port location.

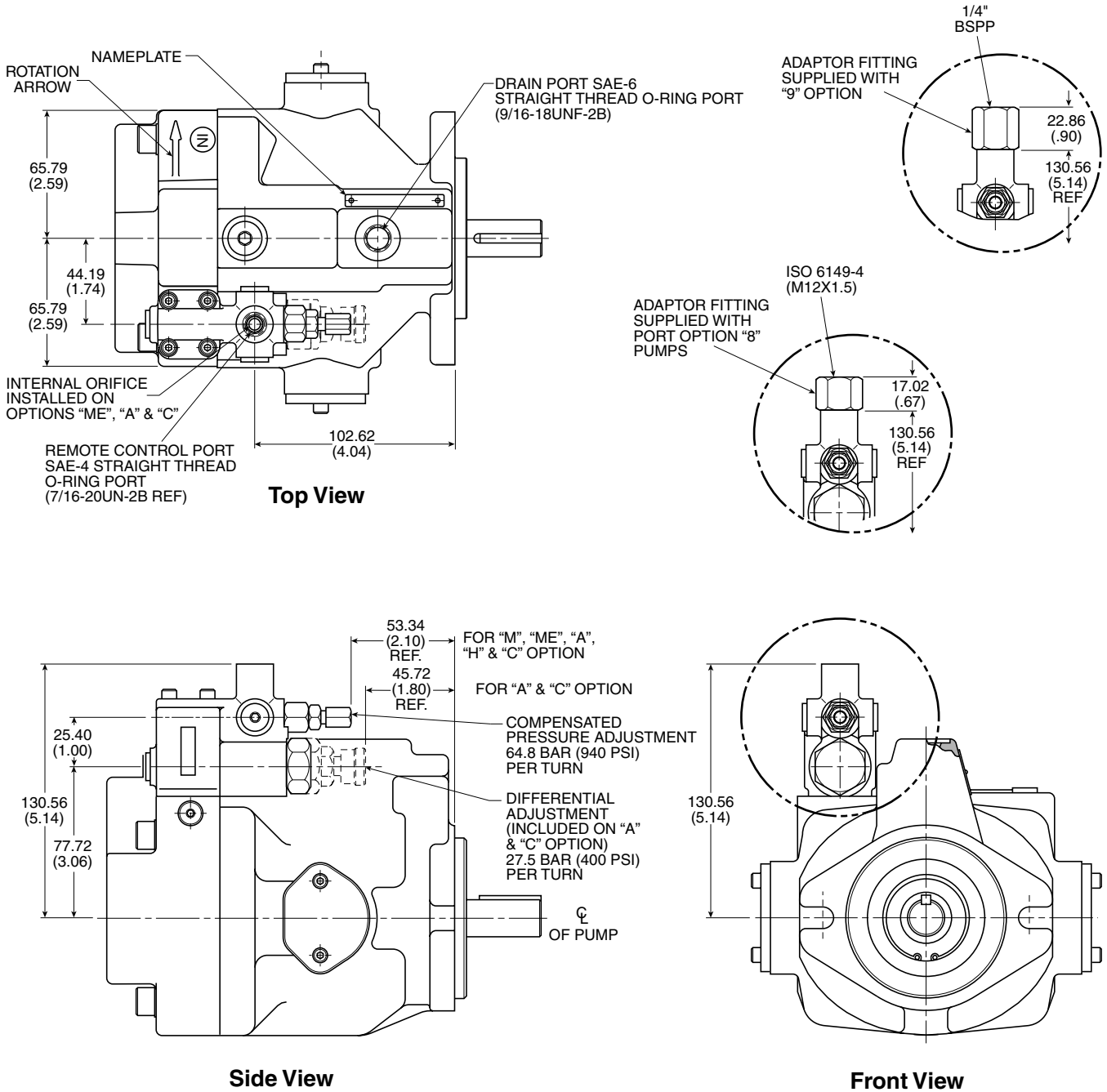

Power (Torque) Control Pump Dimensions

* Inch equivalents for millimeter dimensions are shown in (**).

NOTES:

1. Righthand (CW) rotation rear ported pump shown. Counterclockwise (CCW) pumps will have inlet and outlet ports reversed with compensator and power block on outlet side.
2. Power control shown on rear ported pump. Also available on side ported or thru-shaft option pumps.

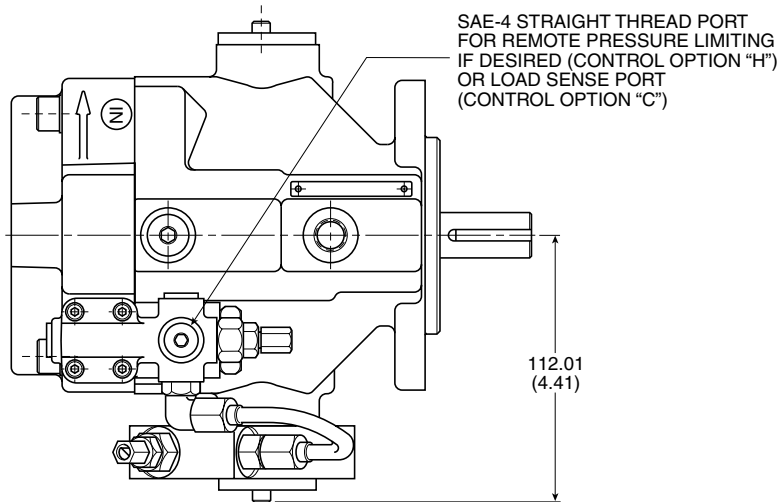

Top View

TORQUE LIMIT ADJUSTMENT CONTROL OPTION "H" SENSITIVITY APPROX. 21.4 N-m (190 IN-LB) PER TURN

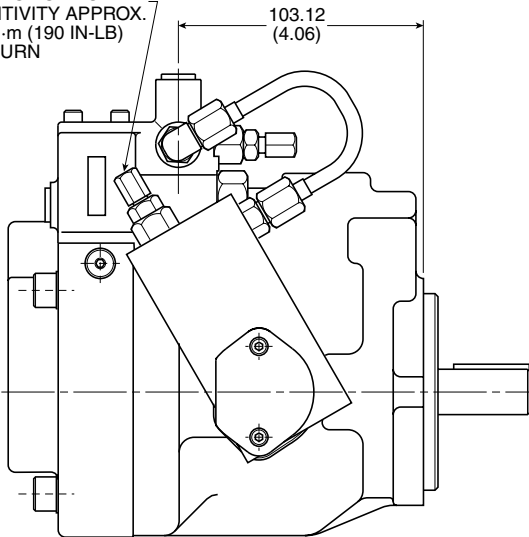

Side View

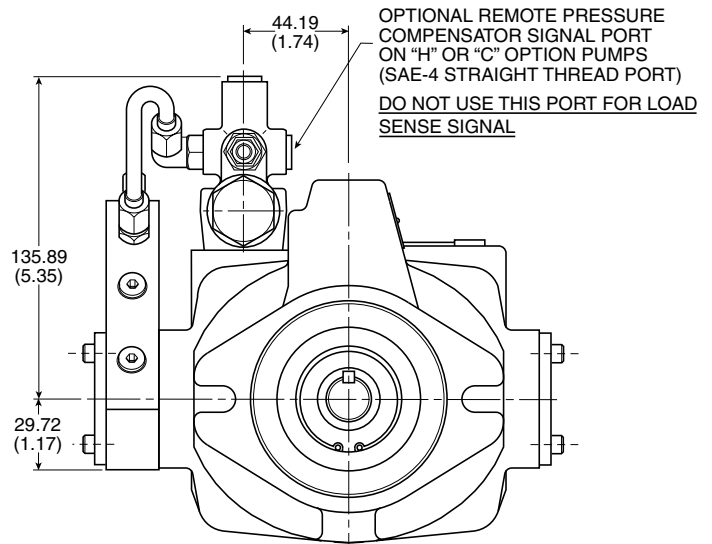

Front View

Performance Information

Series PVP 23/33 Pressure Compensated, Variable Volume, Piston Pumps

Features

- High Strength Cast-Iron Housing for Reliability and Quiet Operation
- Optional Inlet/Outlet Locations for Ease of Installation
- Replaceable Bronze Port Plate
- Replaceable Piston Slipper Plate
- Thru-Shaft Capability SAE A and B Pilots Offered
- Low Noise Levels
- Fast Response Times
- Metric Pilot Shaft and Ports Available

Controls

- Pressure Compensation
- Remote Pressure Compensation
- Load Sensing
- Torque (Power) Limiting
- Adjustable Maximum Volume Stop
- Low Pressure Standby

Schematic Symbol

(Basic Pump)

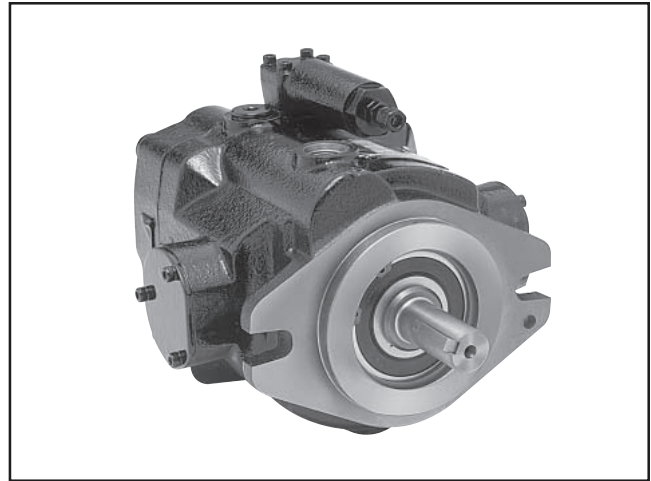
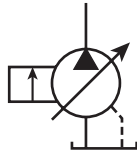

Specifications

Pressure Ratings

Outlet Port: 248 bar (3600 PSI) Continuous (P1)
 310 bar (4500 PSI) Peak (P3)

Inlet Port: 1.72 bar (25 PSI) Maximum
 .17 bar (5 In. Hg.) Vacuum Minimum
 @ 1800 RPM (See inlet chart for other speeds)

Speed Ratings: 600 to 3000 RPM

Operating Temperature Range: - 40°C to 71°C
 (- 40°F to 160°F)

Housing Material: Cast-Iron

Filtration: Maintain SAE Class 4,
 ISO 16/13,
 ISO 18/15 Maximum

Mounting: SAE "B" or Metric 2-Bolt
 Flange Mount

Installation Data: See page 42 of this catalog for specific recommendations pertaining to system cleanliness, fluids, start-up, inlet conditions, shaft alignment, drain line restrictions and other important factors relative to the proper installation and use of these pumps.

Quick Reference Data Chart

Pump Model	Displacement cc/rev (In ³ /rev)	Pump Delivery @ 21 bar (300 PSI) in LPM (GPM)		† Approx. Noise Levels dB(A) @ Full Flow 1800 RPM (1200 RPM)					Input Power At 1800 RPM, Max. Displacement & 248 bar (3600 PSI)
		1200 RPM	1800 RPM	34 bar (500 PSI)	69 bar (1000 PSI)	138 bar (2000 PSI)	207 bar (3000 PSI)	248 bar (3600 PSI)	
PVP23	23.0 (1.4)	28.0 (7.4)	42.0 (11.1)	61 (57)	64 (59)	67 (63)	69 (65)	70 (65)	19.7 kw (26.5 hp)
PVP33	33.0 (2.0)	39.4 (10.4)	59.0 (15.6)	64 (59)	66 (59)	68 (62)	70 (64)	71 (65)	27.2 kw (36.5 hp)

† Measured in an anechoic chamber to DIN 45635, measuring error ± 2 dB(A).
 Fluid used: petroleum oil to ISO VG 46; temperature = 50°C (122°F).

Since many variables such as mounting, tank style, plant layout, etc., effect noise levels, it cannot be assumed that the above readings will be equal to those in the field. The above values are for guidance in selecting the proper pump.

hpm102-1.p65, lw, jk

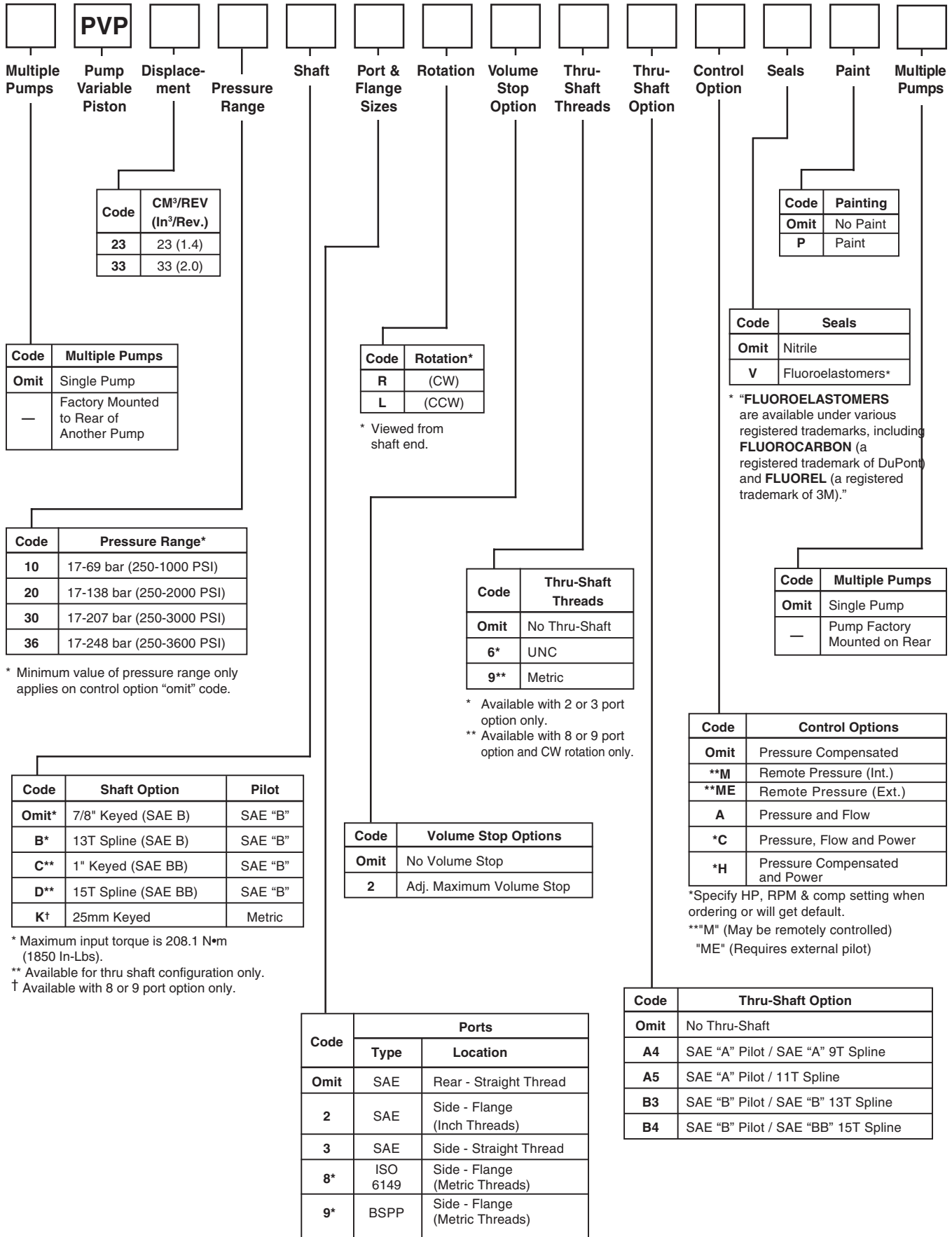

Typical Performance Data - Fluid: Standard Hydraulic Oil 100 SSU @ 49°C (120°F)

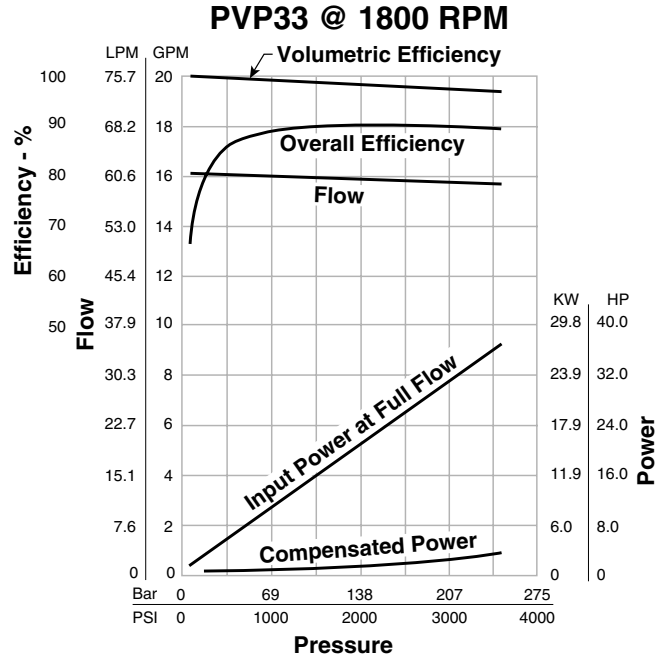
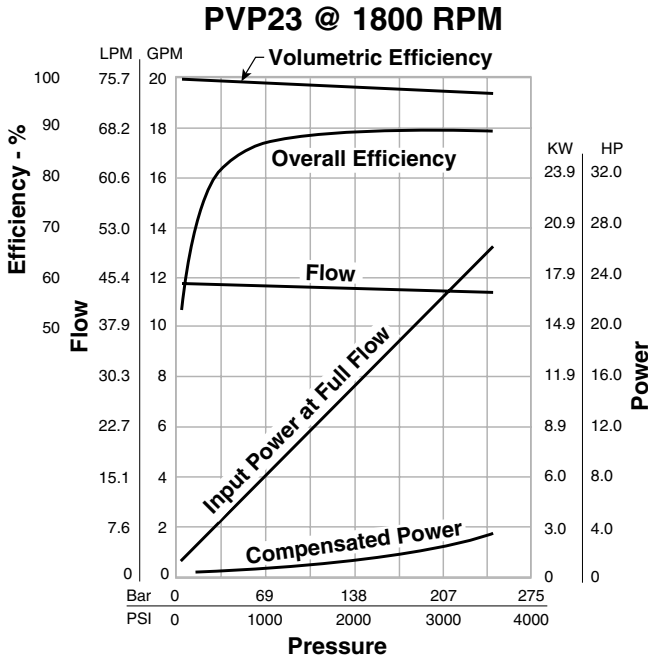

NOTE: The efficiencies and data in the graph are good only for pumps running at 1800 RPM and stroked to maximum. To calculate approximate horsepower for the other conditions, use the following formula:

$$HP = \left[\frac{Q \times (PSI)}{1714} \right] + (CHp)$$

Actual GPM is directly proportional to drive speed and maximum volume setting. Flow loss, however, is a function of pressure only.

WHERE:

Q = Actual Output Flow in GPM

PSI = Pressure At Pump Outlet

CHp = Input Horsepower @ Full Compensation @ 1800 RPM (from graph read at operating pressure)

**PVP 23/33
 Inlet Characteristics at Full Displacement
 (Graph only valid at sea level)**

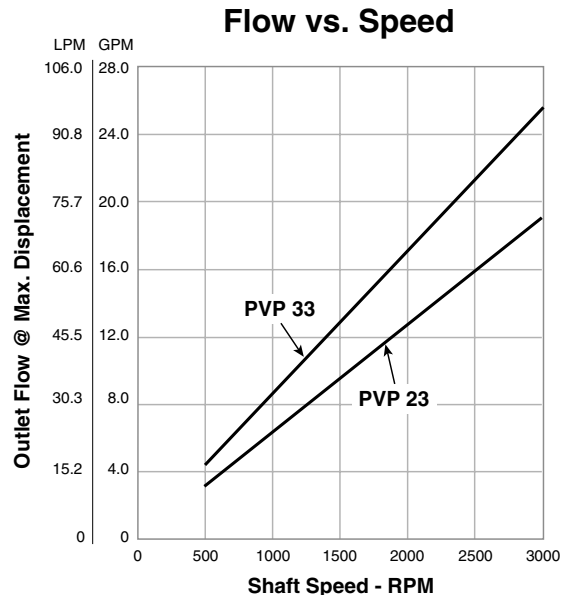
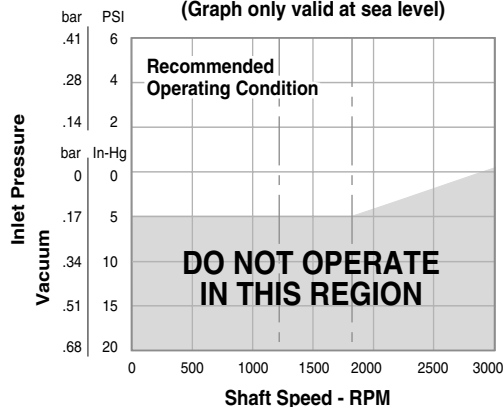

Typical Performance Data - Fluid: Standard Hydraulic Oil 100 SSU @ 49°C (120°F)

Power Control

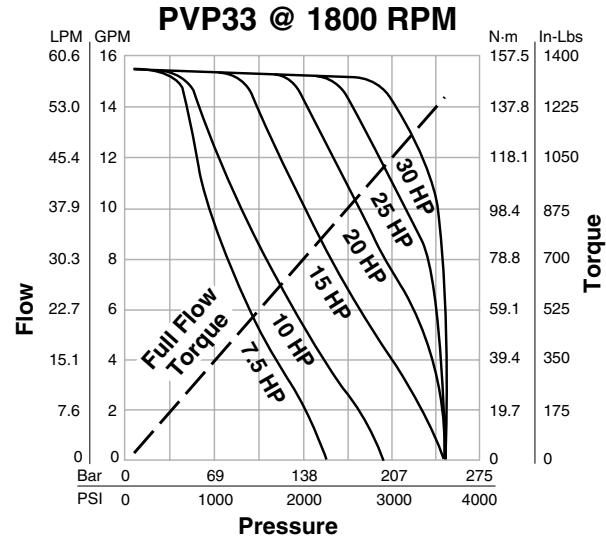
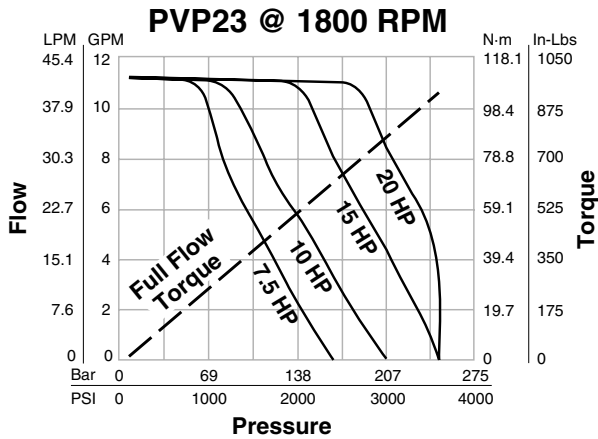

Response Times

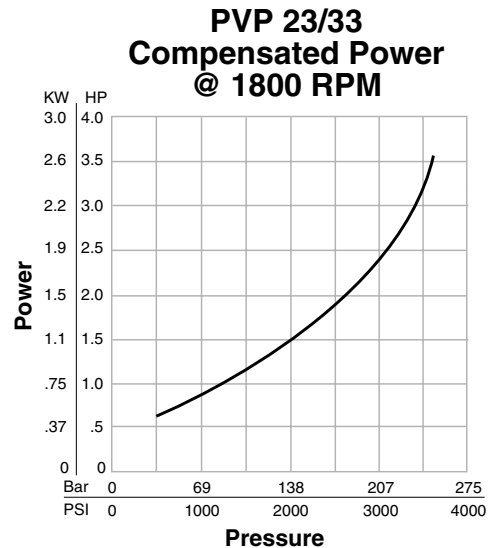
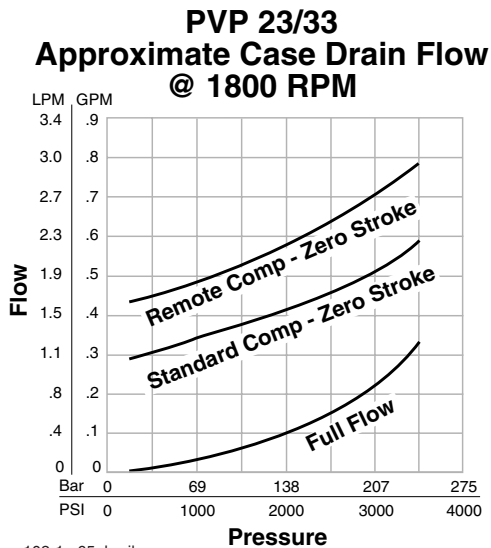
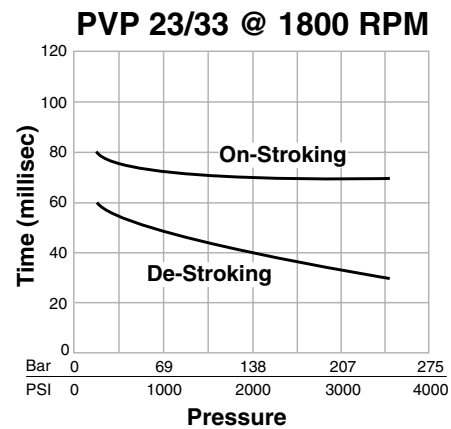
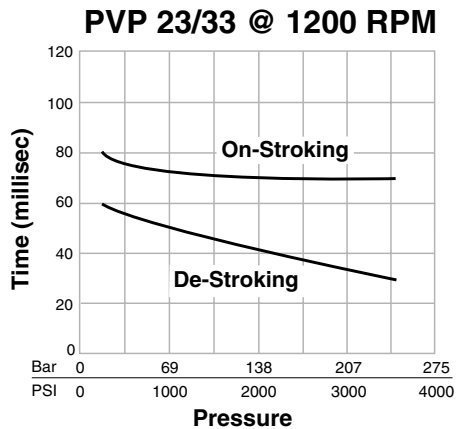

Rear Ported Pump Dimensions

* Inch equivalents for millimeter dimensions are shown in (**).

NOTES:

1. Righthand (CW) rotation pump shown. Lefthand (CCW) pumps have inlet and outlet ports reversed.
2. Pump shown with standard pressure compensator (control option "omit").

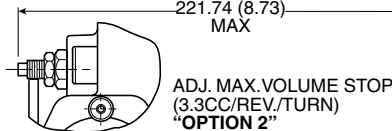
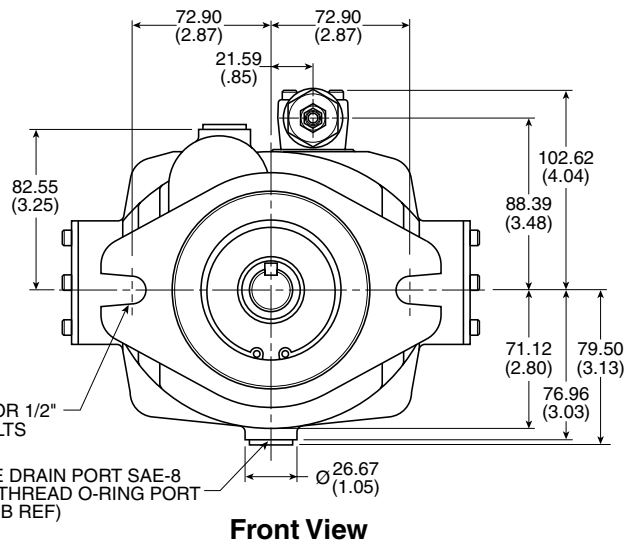
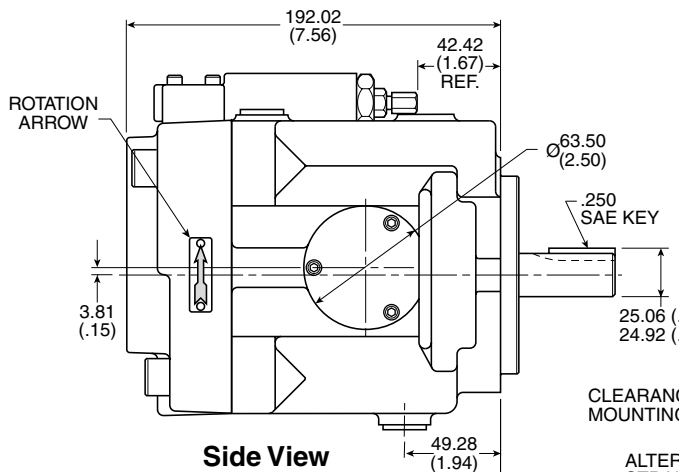
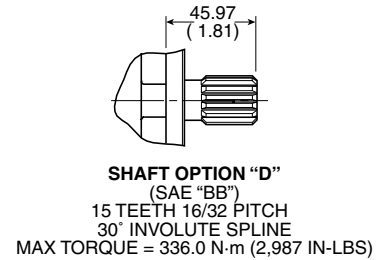
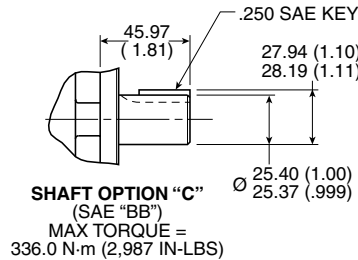
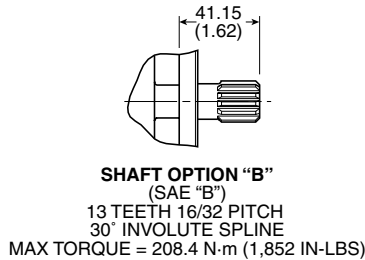
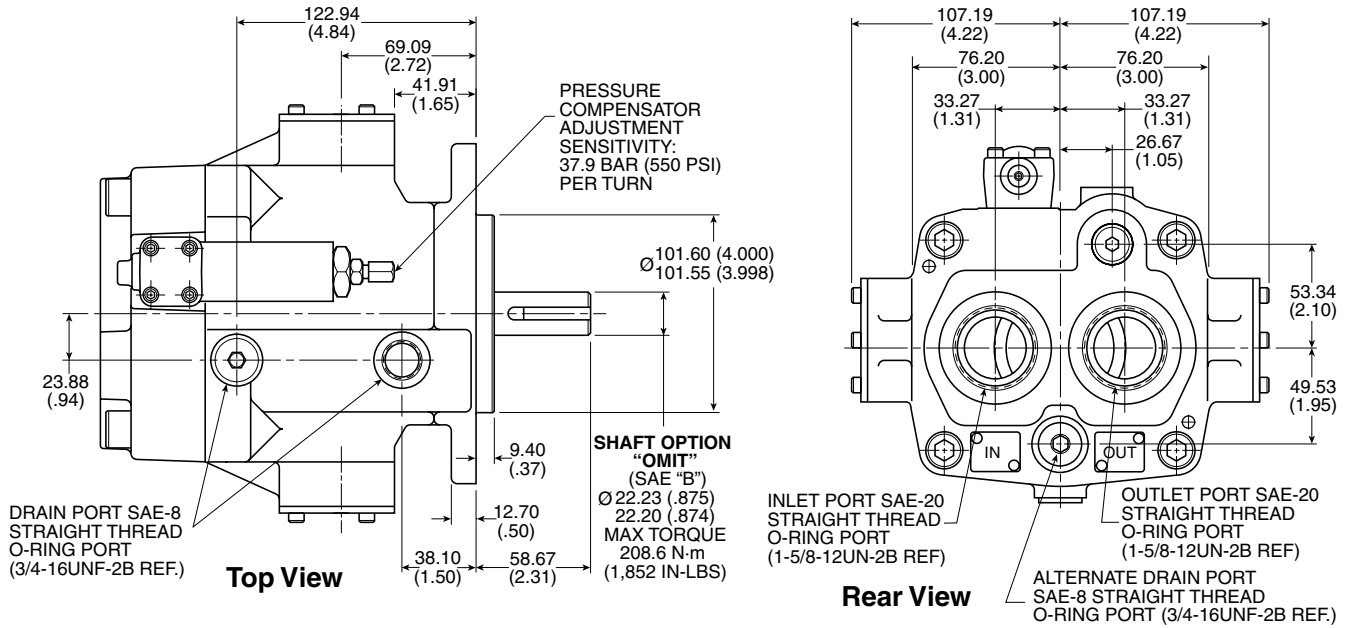

Side Ported – Options 2 & 3 Dimensions

* Inch equivalents for millimeter dimensions are shown in (**).

NOTES:

1. Righthand (CW) rotation pump shown. Lefthand (CCW) pumps have inlet and outlet ports reversed.
2. Pump shown with standard pressure compensator (control option "omit").

Port Location		
Option	A	Inlet and Outlet Port
2	148.84 (3.10)	1-1/4" SAE 4-Bolt Flange 7/16-14 Threads Standard Pressure Series (Code 61)
3	152.40 (3.22)	SAE-20 Straight Thread (1-5/8-12UN-2B)

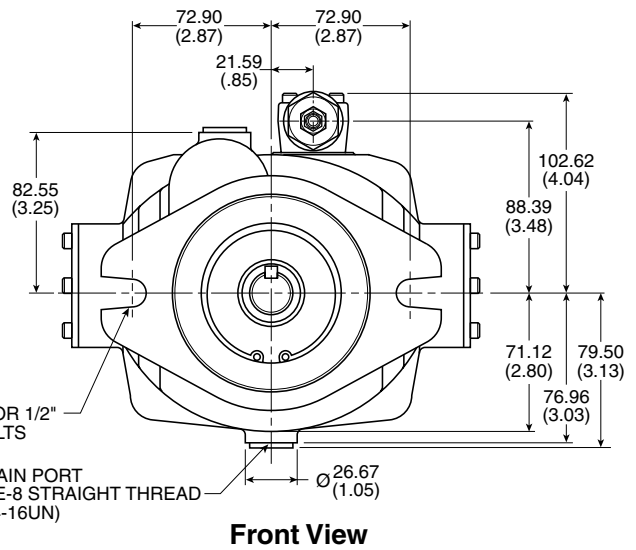
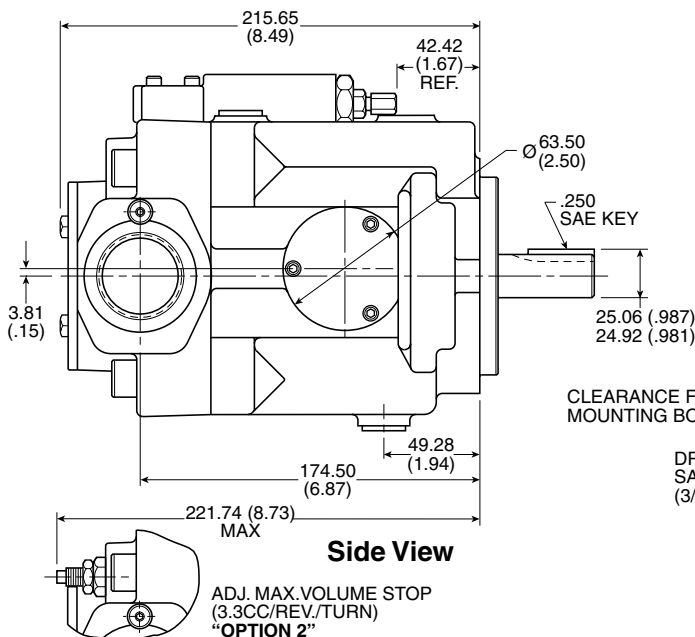
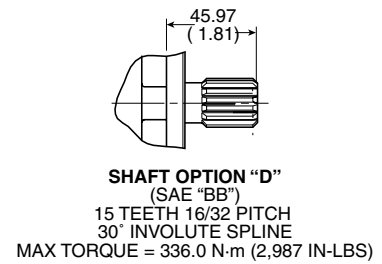
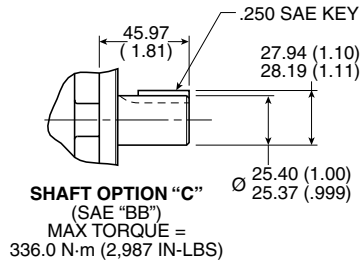
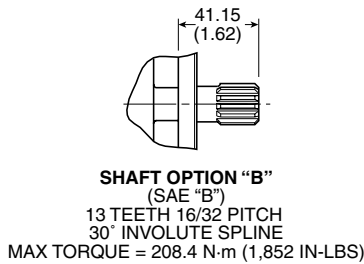
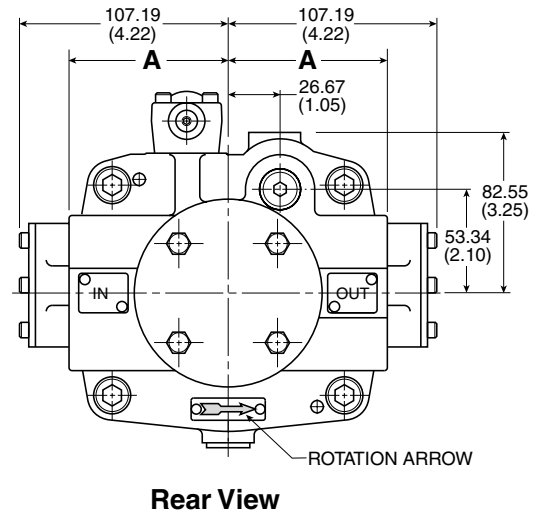
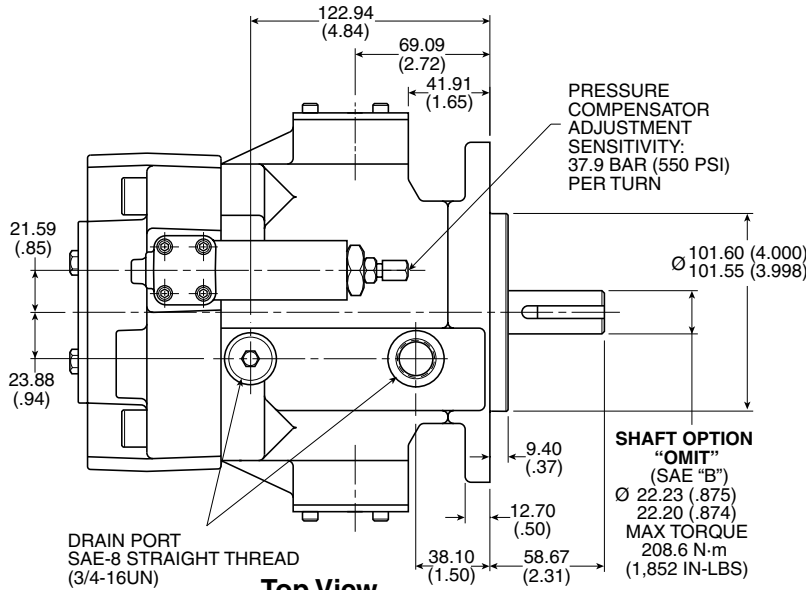

Side Ported – Options 8 & 9 Dimensions

* Inch equivalents for millimeter dimensions are shown in (**).

NOTES:

1. Righthand (CW) rotation pump shown.
2. Pump shown with standard pressure compensator (control option "omit").

Shaft Option	Pilot Dimensions			
	A	B	C	D
Omit	101.60/101.55 (4.000/3.998)	9.40 (.37)	72.90 (2.87)	ø 12.70 (.50)
K	100.00/99.95 (3.937/3.935)	9.14 (.36)	69.85 (2.75)	ø 12mm

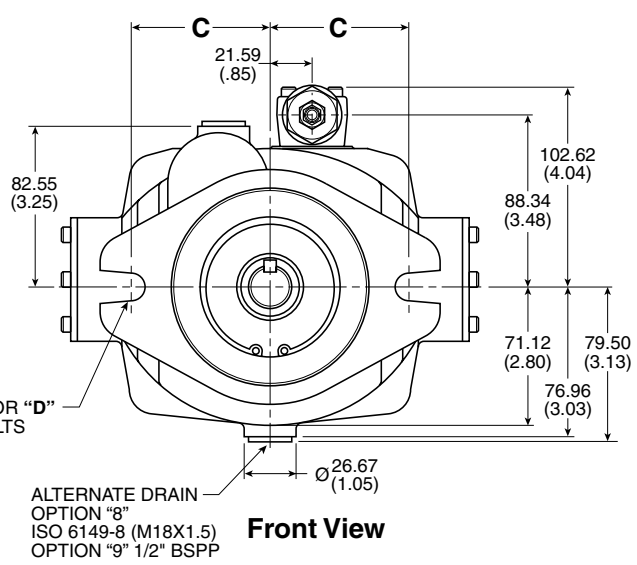
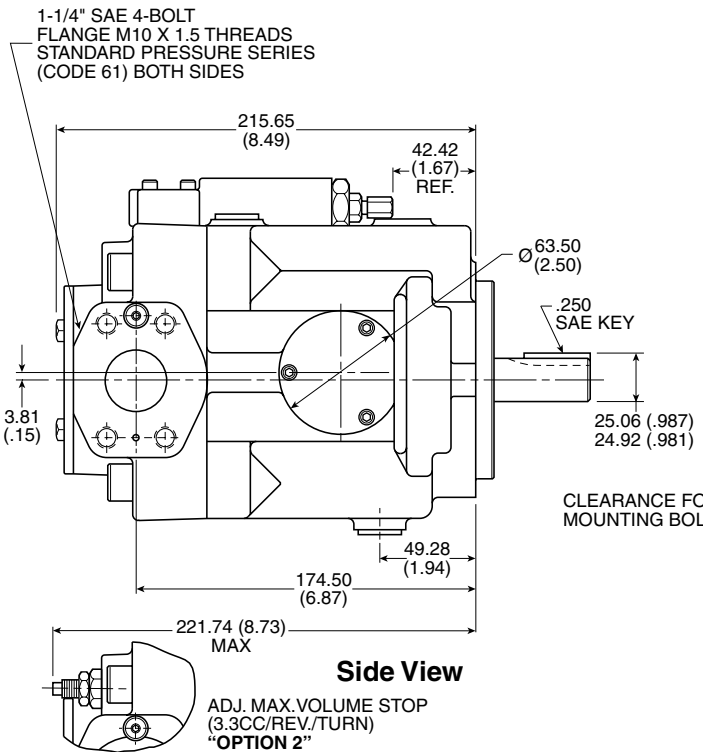
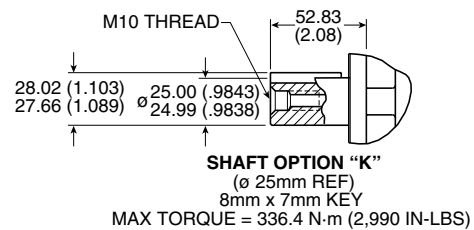
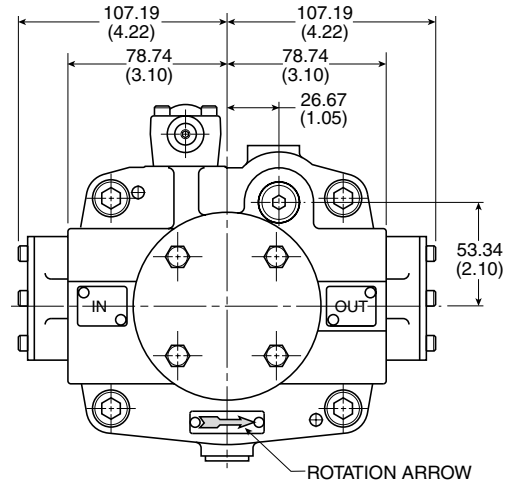
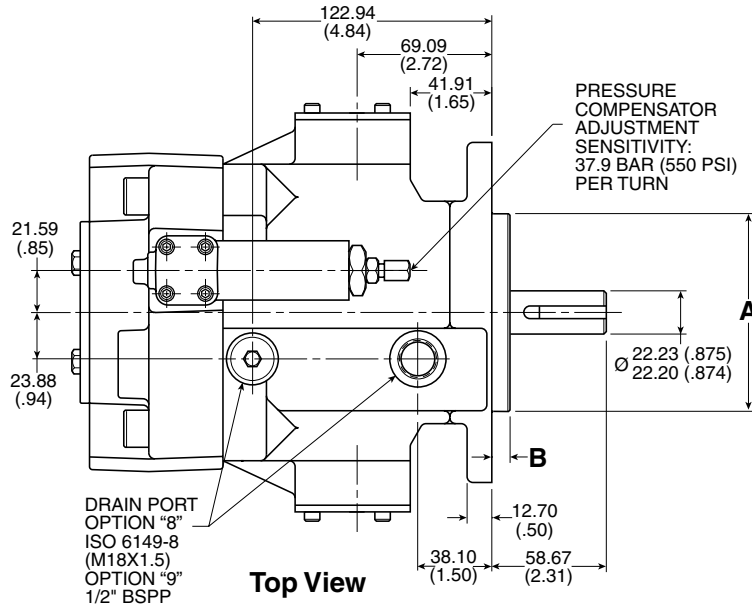

Thru-Shaft Pump Dimensions

* Inch equivalents for millimeter dimensions are shown in (**).

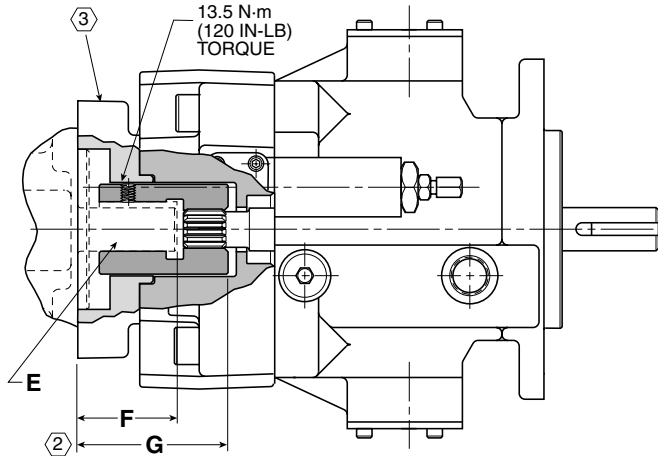

Top View

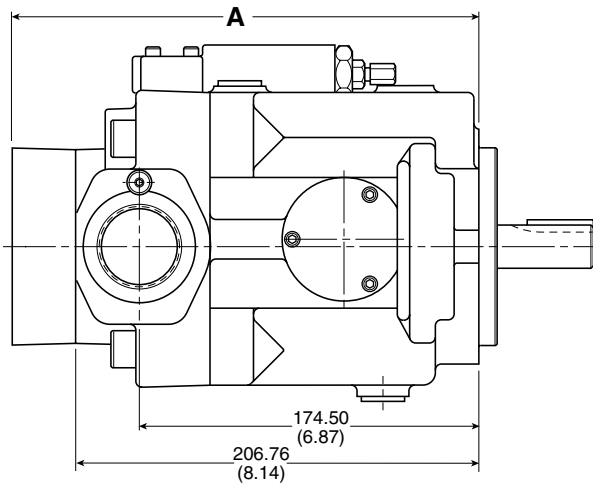

Side View

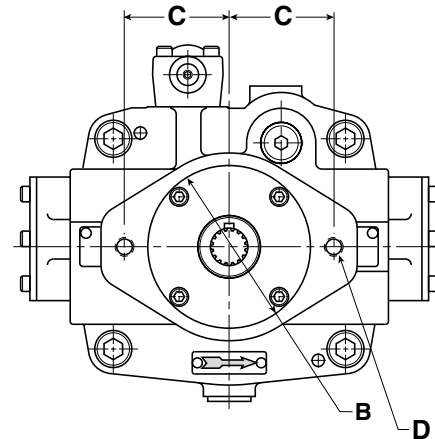

Rear View

NOTES:

1. Righthand (CW) rotation side ported pump shown. Lefthand (CCW) pump will have inlet and outlet ports reversed.
- ② Install coupler on shaft of rear pump to dimension shown then lock down coupler using set screws.
- ③ Options, 6A2, 6A4, 9A4 and 9A5 Design Series 20 have a gasket seal, all other thru-shaft options incorporate an o-ring seal and have an o-ring groove.
4. Maximum torque transmitting capacity 209 N·m (1850 in-lbs).

Thru-Shaft Options							
Variation	A	B	C	D	E	F	G
6A4	238.51 (9.39)	82.58/82.60 (3.251/3.252)	53.19 (2.09)	3/8-16UNC-2B	9 Tooth 16/32 Pitch	31.75 (1.25)	N/A
6A5	238.51 (9.39)	82.58/82.60 (3.251/3.252)	53.19 (2.09)	3/8-16UNC-2B	11 Tooth 16/32 Pitch	31.75 (1.25)	N/A
6B3	252.48 (9.94)	101.63/101.65 (4.001/4.002)	73.03 (2.88)	1/2-13UNC-2B	13 Tooth 16/32 Pitch	41.15 (1.62)	N/A
6B4	252.48 (9.94)	101.63/101.65 (4.001/4.002)	73.03 (2.88)	1/2-13UNC-2B	15 Tooth 16/32 Pitch	45.97 (1.81)	N/A
9A4	238.51 (9.39)	82.58/82.60 (3.251/3.252)	53.19 (2.09)	M10 x 1.50	9 Tooth 16/32 Pitch	31.75 (1.25)	N/A
9A5	238.51 (9.39)	82.58/82.60 (3.251/3.252)	53.19 (2.09)	M10 x 1.50	11 Tooth 16/32 Pitch	31.75 (1.25)	N/A
9B3	252.48 (9.94)	101.63/101.65 (4.001/4.00)	73.03 (2.88)	M12 x 1.75	13 Tooth 16/32 Pitch	41.15 (1.62)	N/A
9B4	252.48 (9.94)	101.63/101.65 (4.001/4.00)	73.03 (2.88)	M12 x 1.75	15 Tooth 16/32 Pitch	45.97 (1.81)	N/A

Remote Compensator Control Pump Dimensions

* Inch equivalents for millimeter dimensions are shown in (**).

NOTES:

1. Righthand (CW) rotation rear ported pump shown. Lefthand (CCW) pumps will have inlet and outlet ports reversed.
2. When controlling pump compensator pressure with remote relief valve, size relief valve to pass a minimum of 1.89 LPM (.5 GPM).
3. Remote compensator shown on rear ported pump. Also available on side ported or thru-shaft option pumps.

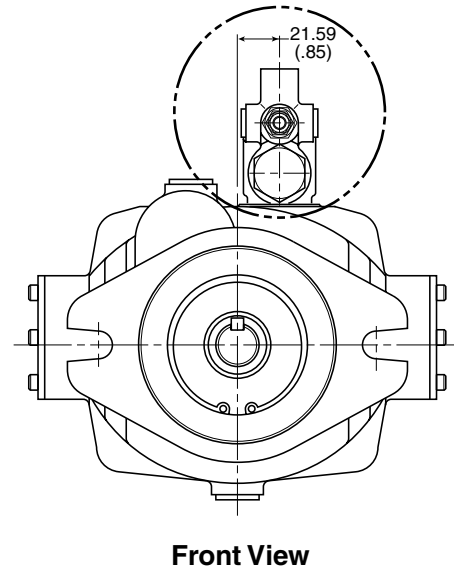
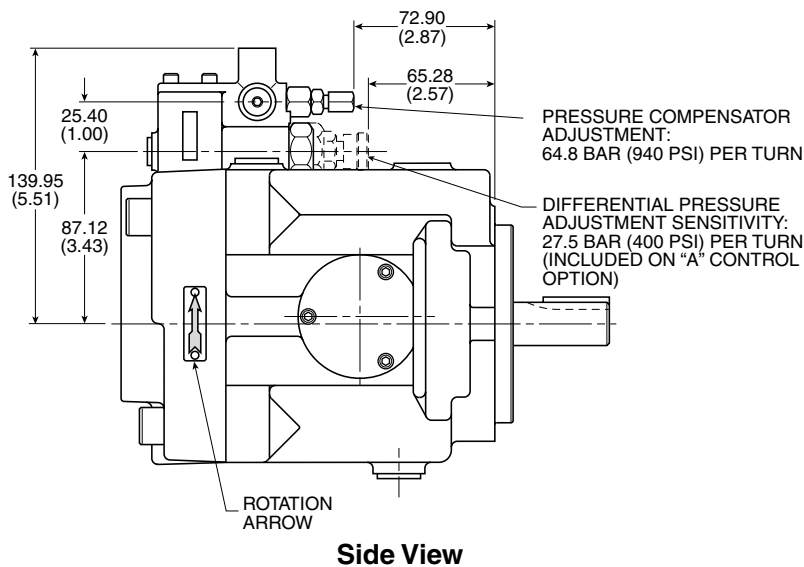
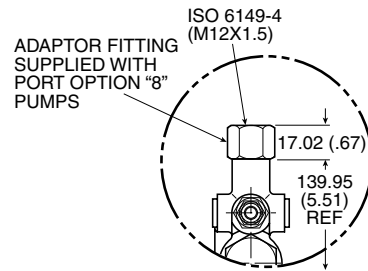
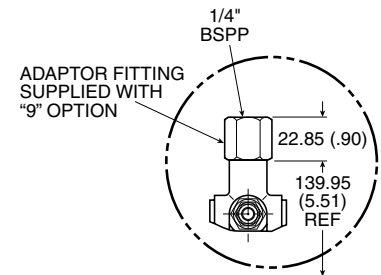
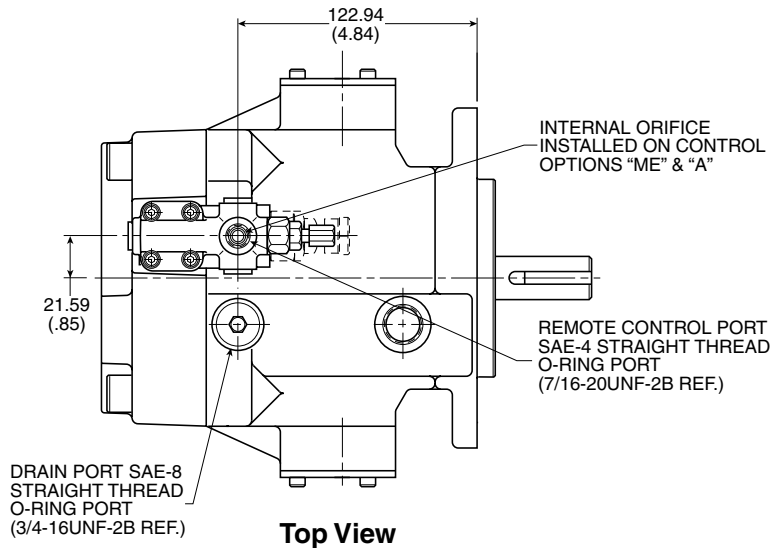

Power (Torque) Control Pump Dimensions

* Inch equivalents for millimeter dimensions are shown in (**).

NOTES:

1. Righthand (CW) rotation rear ported pump shown. Lefthand (CCW) pumps will have inlet and outlet ports reversed.
2. Power control shown on rear ported pump. Also available on side ported or thru-shaft option pumps.

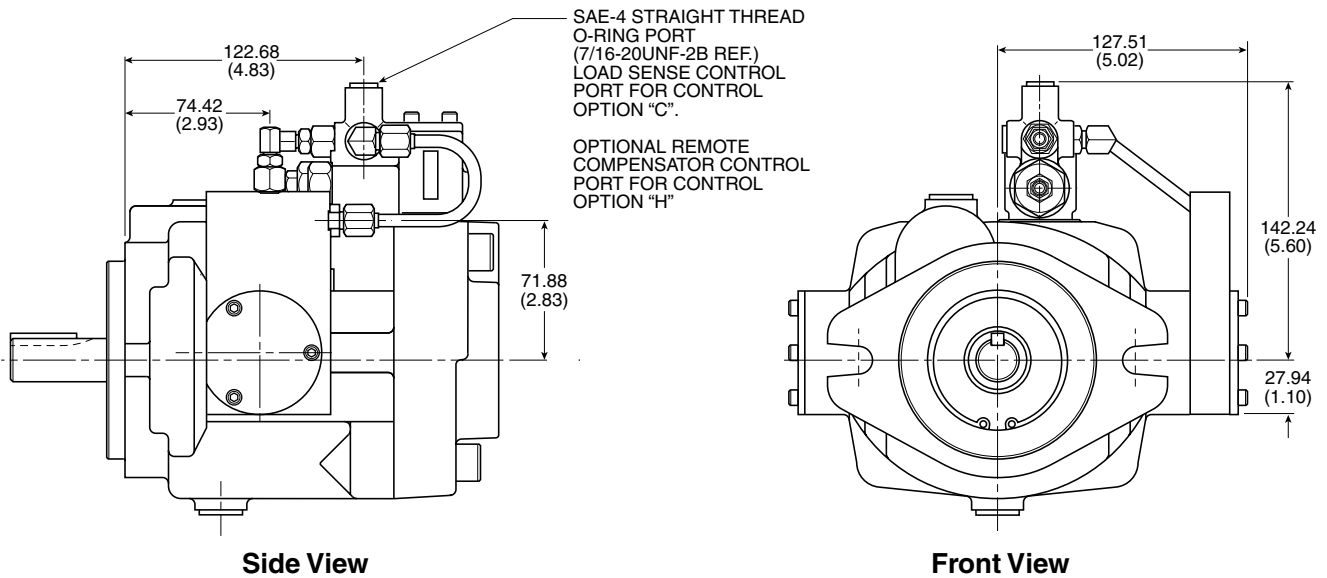
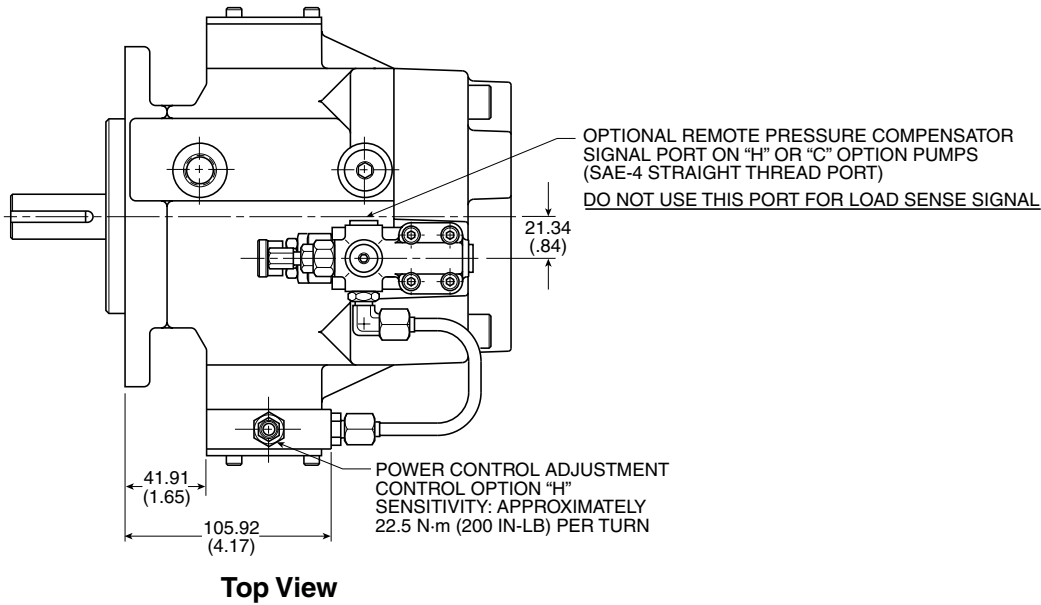

Performance Information

Series PVP 41/48 Pressure Compensated, Variable Volume, Piston Pumps

Features

- High Strength Cast-Iron Housing for Reliability and Quiet Operation
- Optional Inlet/Outlet Locations for Ease of Installation
- Replaceable Bronze Port Plate
- Replaceable Piston Slipper Plate
- Thru-Shaft Capability SAE A or B Pilots
- Low Noise Levels
- Fast Response Times
- Metric Pilot Shaft and Ports Available

Controls

- Pressure Compensation
- Remote Pressure Compensation
- Load Sensing
- Torque (Power) Limiting
- Adjustable Maximum Volume Stop
- Low Pressure Standby
- Hi/Lo Torque (Power) Limiting

Schematic Symbol

(Basic Pump)

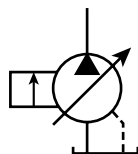

Specifications

Pressure Ratings

Outlet Port: 248 bar (3600 PSI) Continuous (P1)
 310 bar (4500 PSI) Peak (P3)

Inlet Port: 1.72 bar (25 PSI) Maximum
 .17 bar (5 In. Hg.) Vacuum Minimum @ 1800 RPM (See inlet chart for other speeds)

Case Drain Port: .34 bar (5 PSI) Max. above Inlet Port .34 bar (10 PSI) Maximum

Speed Ratings: 600 to 2800 RPM — PVP41
 600 to 2400 RPM — PVP48

Operating Temperature Range: -40°C to 71°C
 (-40°F to 160°F)

Housing Material: Cast-Iron

Filtration: ISO 16/13 Recommended
 ISO 18/15 Maximum

Mounting: SAE "B" or Metric 2-Bolt Flange Mount

Installation Data: See page 42 of this catalog for specific recommendations pertaining to system cleanliness, fluids, start-up, inlet conditions, shaft alignment, drain line restrictions and other important factors relative to the proper installation and use of these pumps.

Quick Reference Data Chart

Pump Model	Displacement cc/rev (In ³ /rev)	Pump Delivery @ 7 bar (100 PSI) in LPM (GPM)		† Approx. Noise Levels dB(A) @ Full Flow 1800 RPM (1200 RPM)					Input Power At 1800 RPM, Max. Displacement & 248 bar (3600 PSI)
		1200 RPM	1800 RPM	34 bar (500 PSI)	69 bar (1000 PSI)	138 bar (2000 PSI)	207 bar (3000 PSI)	248 bar (3600 PSI)	
PVP41	41.0 (2.5)	49.2 (13.0)	73.8 (19.5)	68 (60)	70 (61)	73 (65)	74 (67)	75 (69)	33.2 kw (44.5 hp)
PVP48	48.0 (2.9)	57.6 (15.2)	86.4 (22.8)	69 (60)	71 (62)	73 (65)	75 (68)	76 (69)	40.3 kw (54.0 hp)

† Measured in an anechoic chamber to DIN 45635, measuring error ± 2 dB(A).
 Fluid used: petroleum oil to ISO VG 46; temperature = 50°C (122°F).

Since many variables such as mounting, tank style, plant layout, etc., effect noise levels, it cannot be assumed that the above readings will be equal to those in the field. The above values are for guidance in selecting the proper pump.

hpm102-1.p65, lw, jk

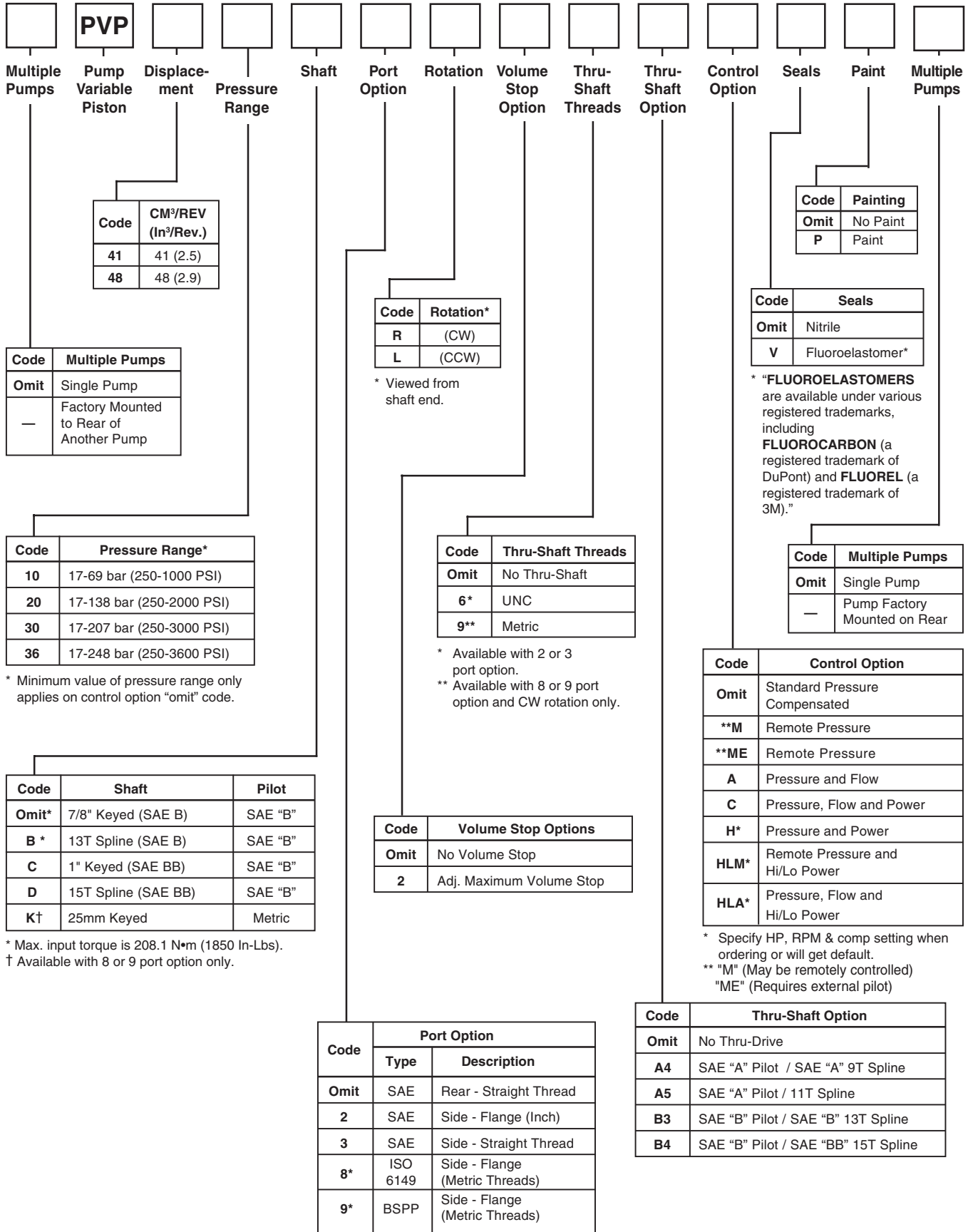

Code	CM ³ /REV (In ³ /Rev.)
41	41 (2.5)
48	48 (2.9)

Code	Multiple Pumps
Omit	Single Pump
—	Factory Mounted to Rear of Another Pump

Code	Pressure Range*
10	17-69 bar (250-1000 PSI)
20	17-138 bar (250-2000 PSI)
30	17-207 bar (250-3000 PSI)
36	17-248 bar (250-3600 PSI)

* Minimum value of pressure range only applies on control option "omit" code.

Code	Shaft	Pilot
Omit*	7/8" Keyed (SAE B)	SAE "B"
B *	13T Spline (SAE B)	SAE "B"
C	1" Keyed (SAE BB)	SAE "B"
D	15T Spline (SAE BB)	SAE "B"
K†	25mm Keyed	Metric

* Max. input torque is 208.1 N•m (1850 In-Lbs).

† Available with 8 or 9 port option only.

Code	Rotation*
R	(CW)
L	(CCW)

* Viewed from shaft end.

Code	Thru-Shaft Threads
Omit	No Thru-Shaft
6*	UNC
9**	Metric

* Available with 2 or 3 port option.

** Available with 8 or 9 port option and CW rotation only.

Code	Volume Stop Options
Omit	No Volume Stop
2	Adj. Maximum Volume Stop

Code	Port Option	
	Type	Description
Omit	SAE	Rear - Straight Thread
2	SAE	Side - Flange (Inch)
3	SAE	Side - Straight Thread
8*	ISO 6149	Side - Flange (Metric Threads)
9*	BSPP	Side - Flange (Metric Threads)

* Available with CW rotation only.

Code	Painting
Omit	No Paint
P	Paint

Code	Seals
Omit	Nitrile
V	Fluoroelastomer*

* "FLUOROELASTOMERS" are available under various registered trademarks, including **FLUOROCARBON** (a registered trademark of DuPont) and **FLUOREL** (a registered trademark of 3M)."

Code	Multiple Pumps
Omit	Single Pump
—	Pump Factory Mounted on Rear

Code	Control Option
Omit	Standard Pressure Compensated
**M	Remote Pressure
**ME	Remote Pressure
A	Pressure and Flow
C	Pressure, Flow and Power
H*	Pressure and Power
HLM*	Remote Pressure and Hi/Lo Power
HLA*	Pressure, Flow and Hi/Lo Power

* Specify HP, RPM & comp setting when ordering or will get default.

** "M" (May be remotely controlled)
 "ME" (Requires external pilot)

Code	Thru-Shaft Option
Omit	No Thru-Drive
A4	SAE "A" Pilot / SAE "A" 9T Spline
A5	SAE "A" Pilot / 11T Spline
B3	SAE "B" Pilot / SAE "B" 13T Spline
B4	SAE "B" Pilot / SAE "BB" 15T Spline

Typical Performance Data - Fluid: Standard Hydraulic Oil 100 SSU @ 49°C (120°F)

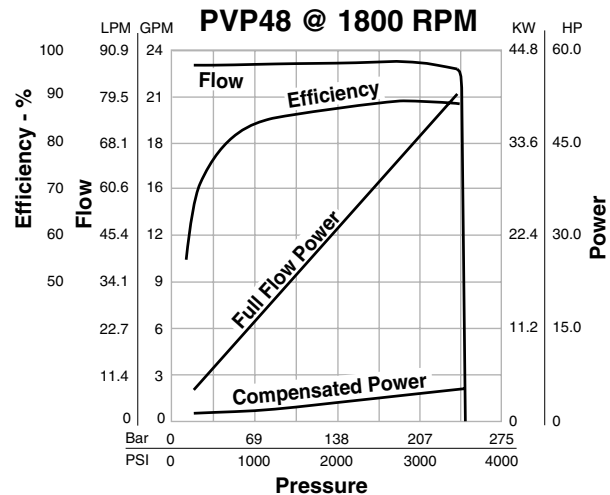
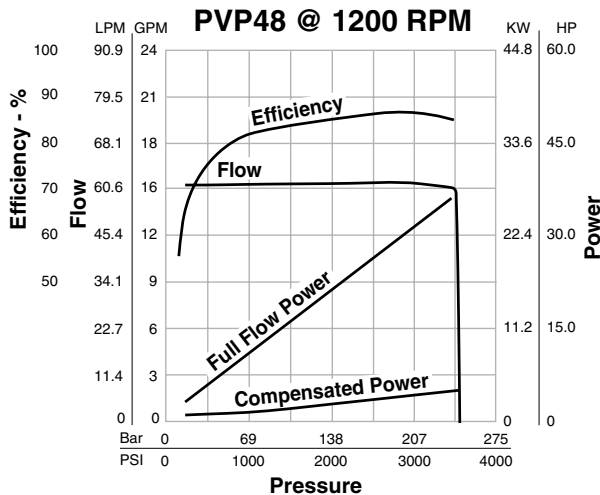
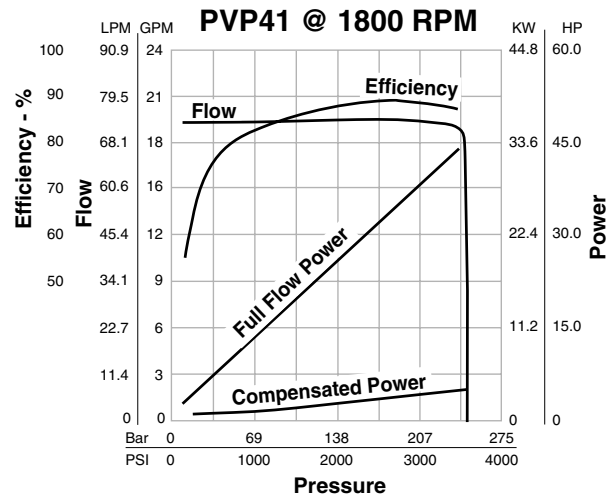
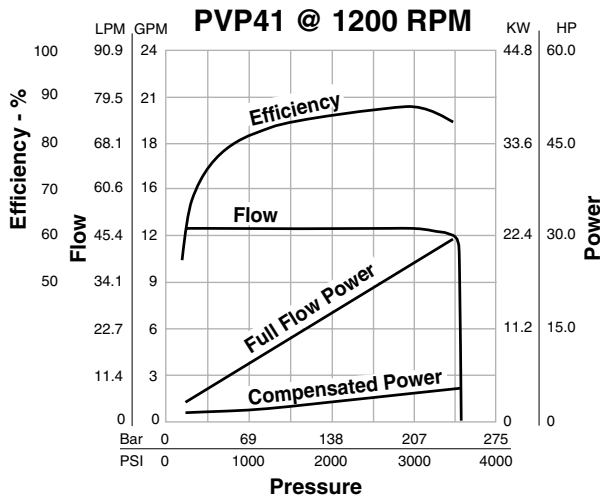

NOTE: The efficiencies and data in the graph are good only for pumps running at 1200 or 1800 RPM and stroked to maximum. To calculate approximate horsepower for the other conditions, use the following formula:

$$HP = \left[\frac{Q \times (PSI)}{1714} \right] + (CHp)$$

Actual GPM is directly proportional to drive speed and maximum volume setting. Flow loss, however, is a function of pressure only.

WHERE:

Q = Actual Output Flow in GPM

PSI = Pressure At Pump Outlet

CHp = Input Horsepower @ Full compensation @ 1800 RPM (from graph read at operating pressure)

**PVP 41/48
 Inlet Characteristics at Full Displacement**
 (Graph only valid at sea level)

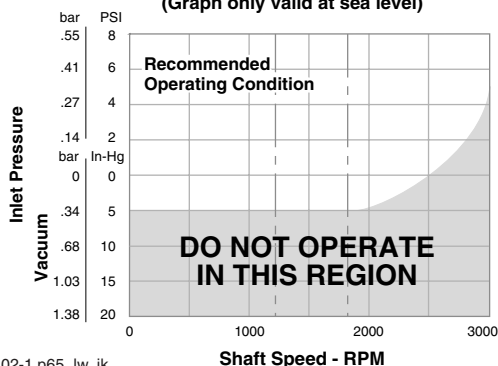

**PVP 41/48
 Flow vs. Shaft Speed**

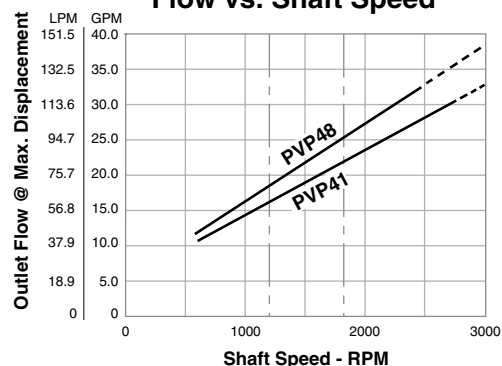

Typical Performance Data - Fluid: Standard Hydraulic Oil 100 SSU @ 49°C (120°F)

Power Control

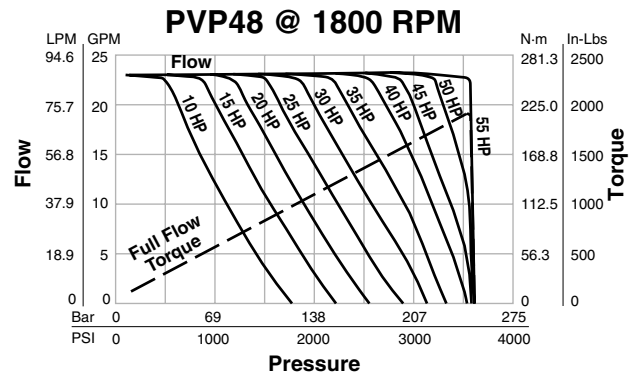
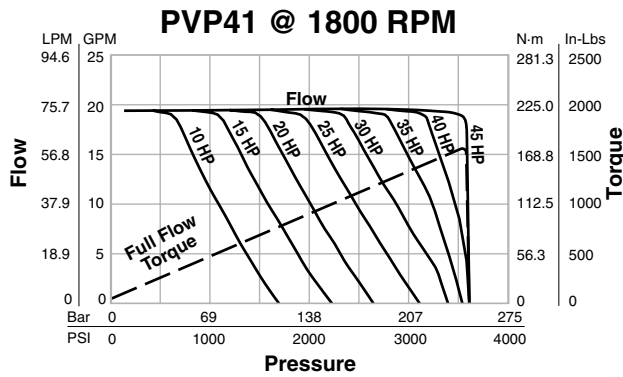

Response Times

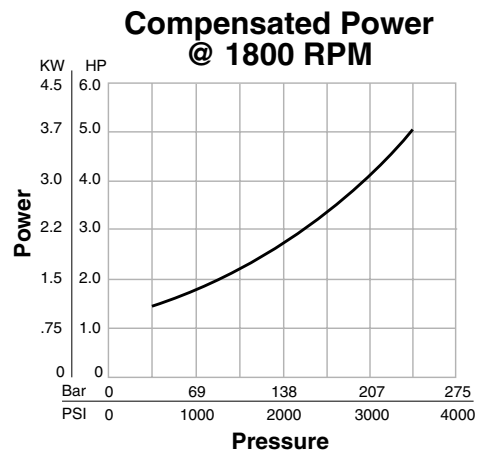
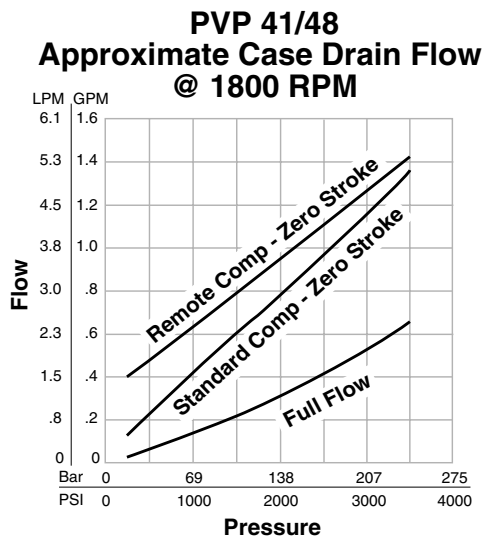
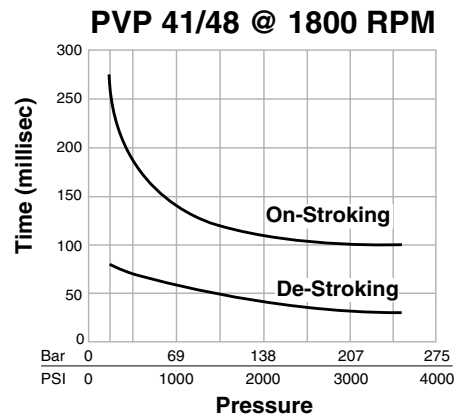
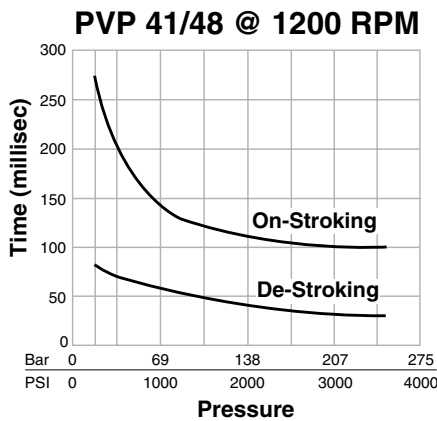

Rear Ported Pump Dimensions

* Inch equivalents for millimeter dimensions are shown in (**).

NOTES:

1. Righthand (CW) rotation pump shown. Lefthand (CCW) rotation pump will have inlet and outlet ports reversed.
2. Pump shown with standard pressure compensator (control option "omit").

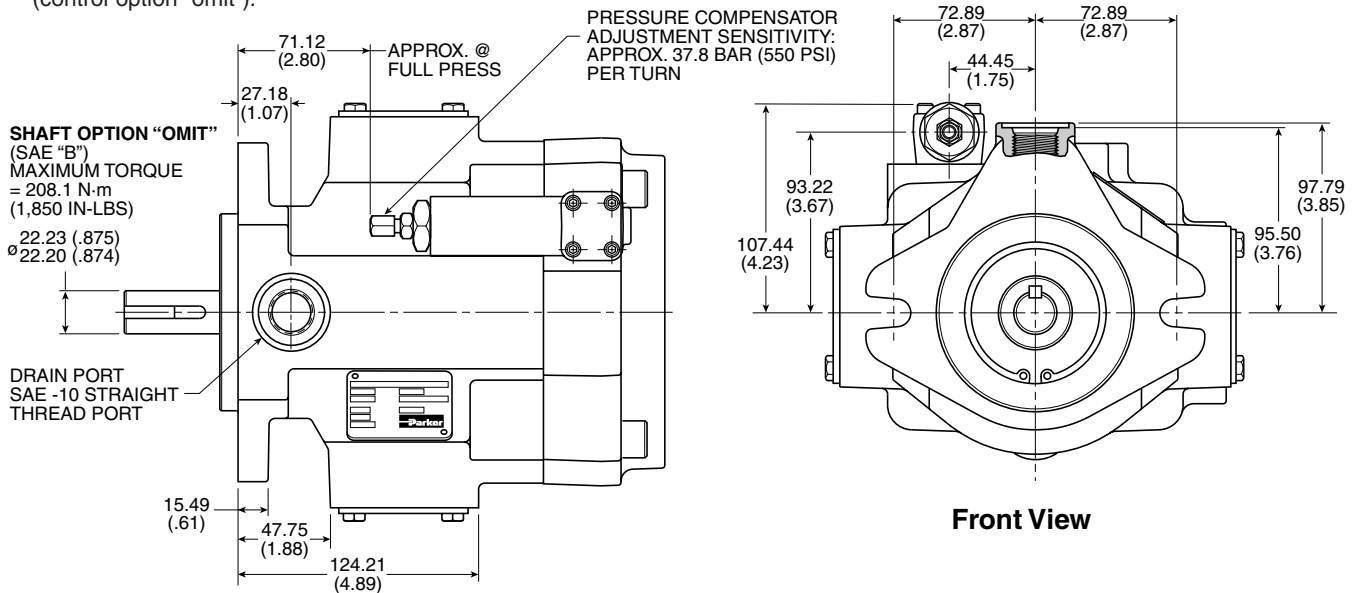

Top View

Front View

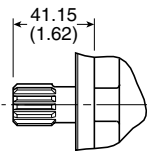

SHAFT OPTION "B"
 (SAE "B") 13 TEETH
 16/32 PITCH
 30° INVOLUTE SPLINE
 MAX. TORQUE = 208.1 N·m (1,850 IN-LBS)

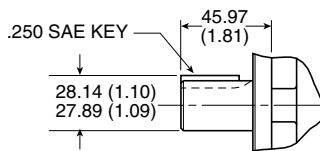

SHAFT OPTION "C"
 (SAE "BB") 15 TEETH
 1" DIA. REF.
 MAX TORQUE = 336.4 N·m (2,990 IN-LBS)

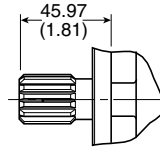

SHAFT OPTION "D"
 (SAE "BB") 15 TEETH
 16/32 PITCH
 30° INVOLUTE SPLINE
 MAX. TORQUE = 336.4 N·m (2,990 IN-LBS)

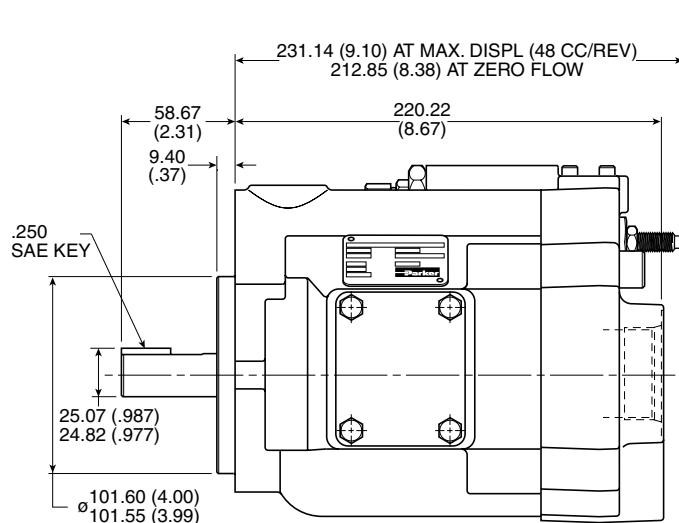

Side View

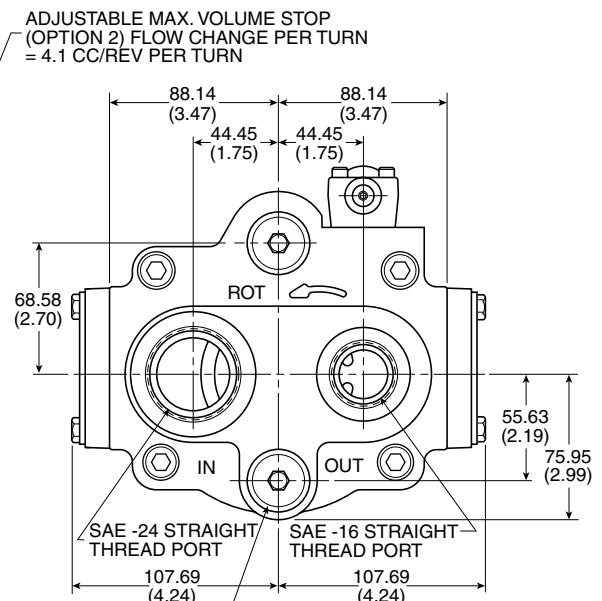

Rear View

OPTIONAL DRAIN PORT FOR
 INVERTED APPLICATIONS
 SAE-10 STRAIGHT THREAD PORT

Side Ported – Options 2 & 3 Dimensions

* Inch equivalents for millimeter dimensions are shown in (**).

NOTES:

1. Righthand (CW) rotation pump shown. Lefthand (CCW) rotation pump will have inlet and outlet ports reversed.
2. Pump shown with standard pressure compensator (control option "omit").

Port Sizes		
Option	Inlet	Outlet
2	1-1/2" SAE 4-Bolt Flange	1" SAE 4-Bolt Flange
	1/2-13 Thread Standard Pressure Series (Code 61)	3/8-16 Thread Standard Pressure Series (Code 61)
3	SAE-24 Straight Thread (1-7/8-12UN-2B)	SAE-16 Straight Thread (1-5/16-12UN-2B)

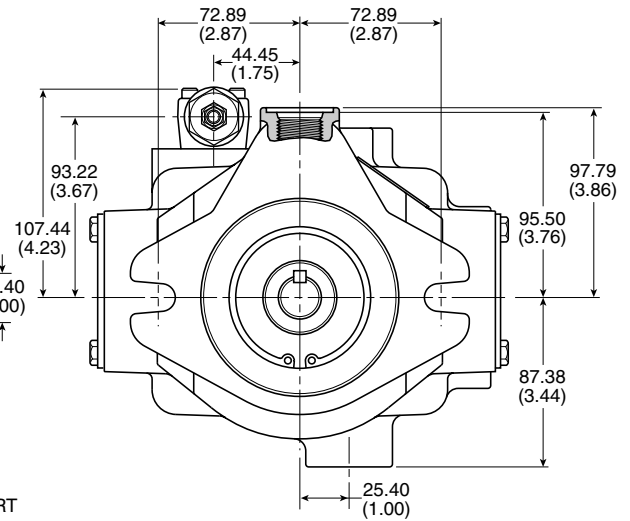
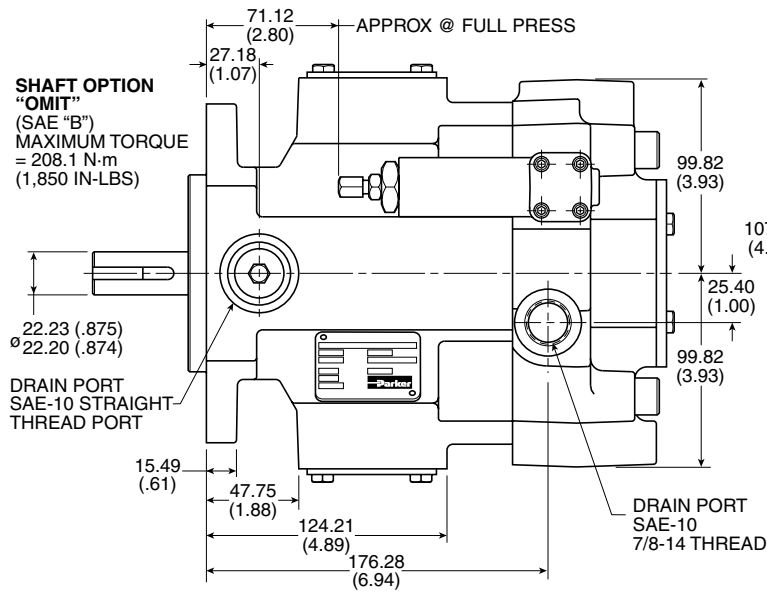

Front View

Top View

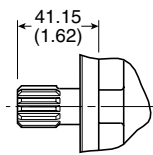

SHAFT OPTION "B"
 (SAE "B") 13 TEETH
 16/32 PITCH
 30° INVOLUTE SPLINE
 MAX. TORQUE = 208.1 N-m (1,850 IN-LBS)

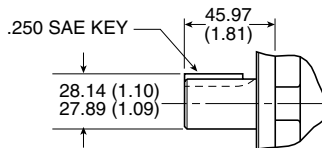

SHAFT OPTION "C"
 (SAE "BB") 1" DIA. REF.
 MAX TORQUE = 336.4 N-m (2,990 IN-LBS)

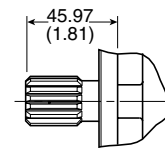

SHAFT OPTION "D"
 (SAE "BB") 15 TEETH
 16/32 PITCH
 30° INVOLUTE SPLINE
 MAX. TORQUE = 336.4 N-m (2,990 IN-LBS)

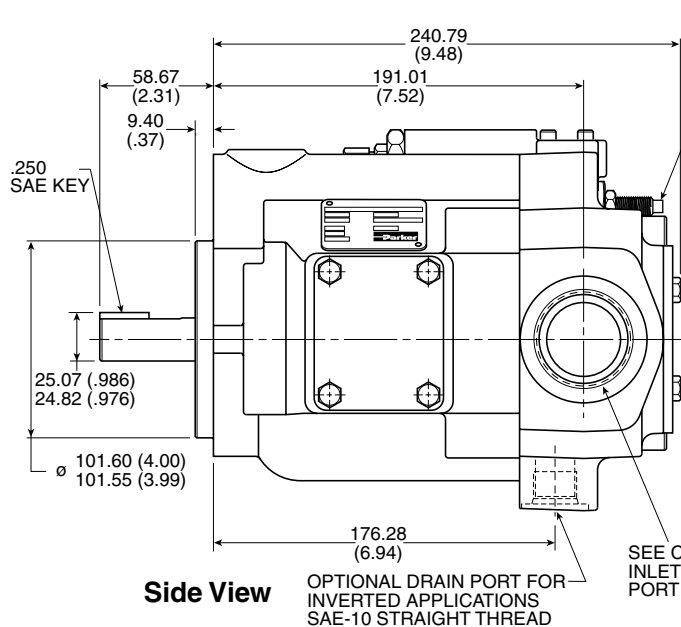

Side View

ADJUSTABLE MAX. VOLUME STOP
 (OPTION 2) FLOW CHANGE PER TURN = 4.1 CC/REV PER TURN

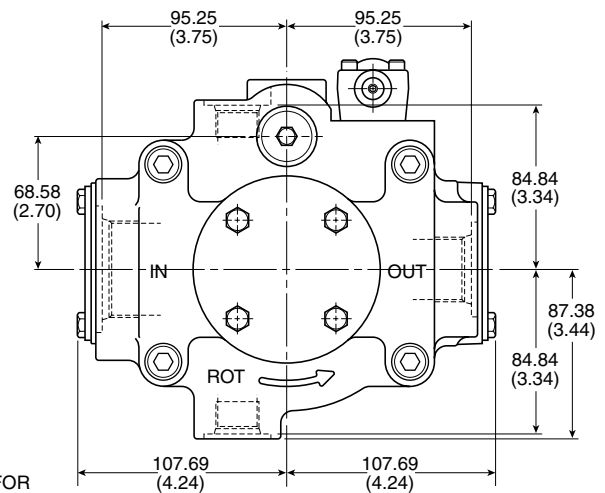

Rear View

SEE CHART FOR INLET & OUTLET PORT SPECIFICATIONS

Side Ported – Options 8 & 9 Dimensions

* Inch equivalents for millimeter dimensions are shown in (**).

NOTES:

1. Righthand (CW) rotation pump shown.
2. Pump shown with standard pressure compensator (control option "omit").

Pilot Dimensions				
Shaft Option	A	B	C	D
Omit	101.60/101.55	9.40	72.90	ø 12.70
B, C, D	(4.000/3.998)	(.37)	(2.87)	(.50)
K	100.00/99.95	9.14	69.85	ø 11.94
	(3.937/3.935)	(.36)	(2.75)	(.47)

Inlet Port	Outlet Port
1-1/2" SAE 4-Bolt Flange M12 Thread Standard Pressure Series (Code 61)	1" SAE 4-Bolt Flange M10 Thread Standard Pressure Series (Code 61)

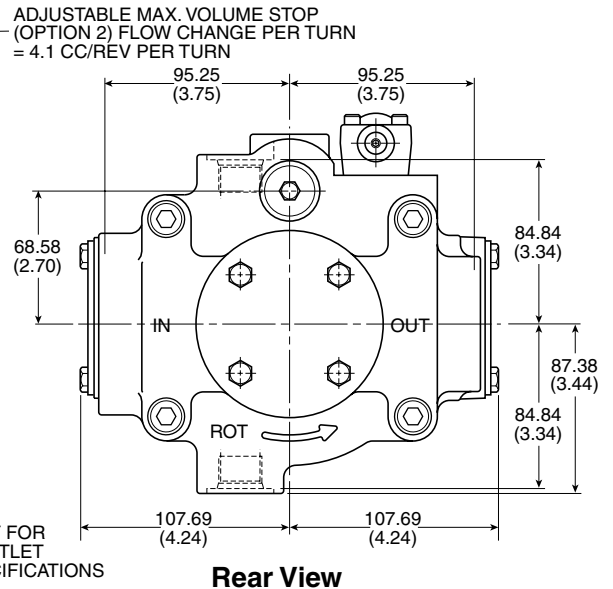
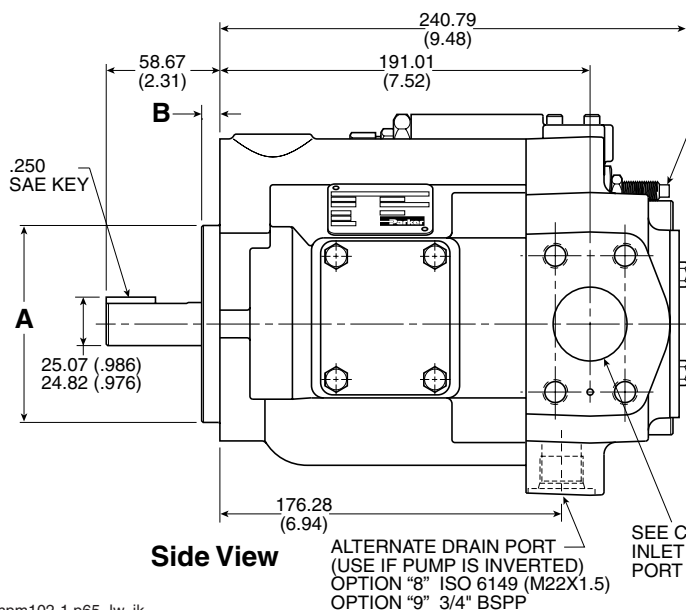
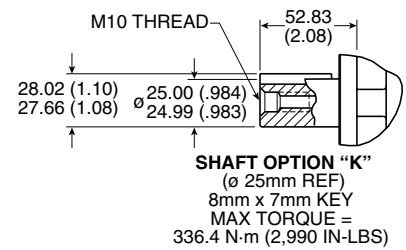
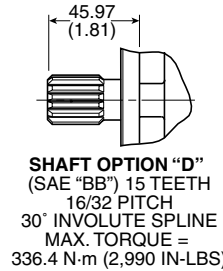
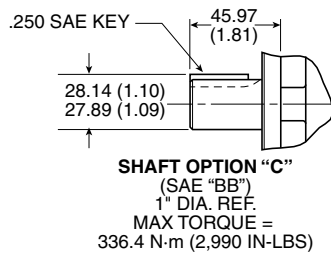
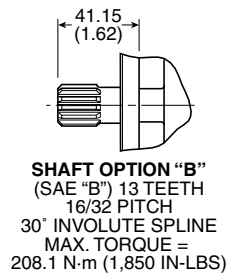
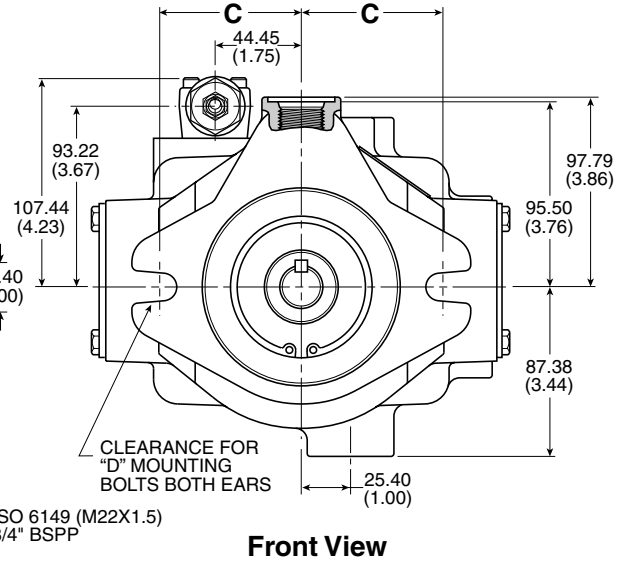
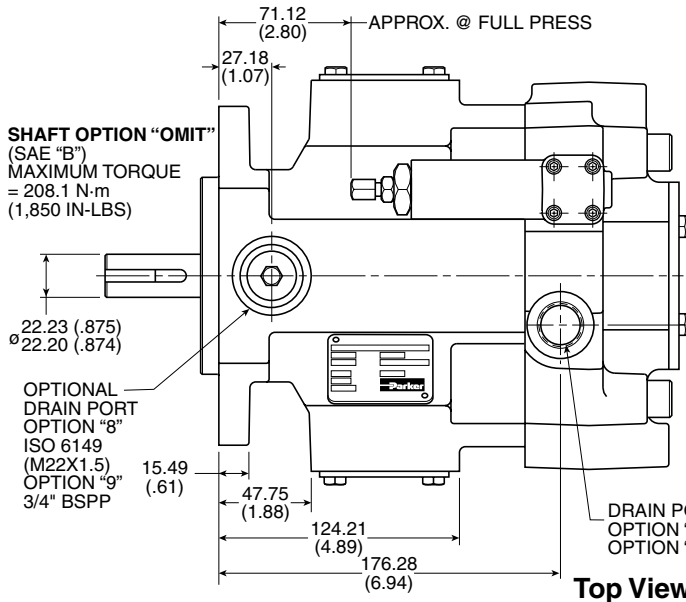

Thru-Shaft Pump Dimensions

* Inch equivalents for millimeter dimensions are shown in (**).

NOTES:

1. Righthand (CW) rotation side ported pump with straight thread ports shown. Lefthand (CCW) pumps will have inlet and outlet ports reversed.
- ② Later versions of Thru-Shaft options 6A4, 6A5, 9A4 and 9A5, incorporate a gasket, P/N 801209 to seal on the rear pump rather than an o-ring.
3. Maximum torque transmitting capacity for rear pumps = 208.1 N•m (1,850 In-Lbs).

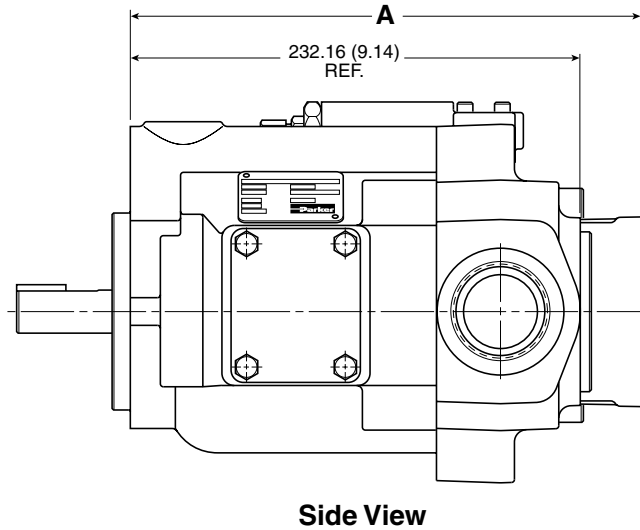
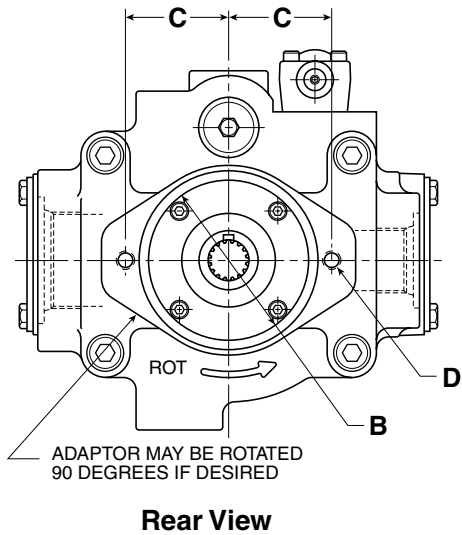
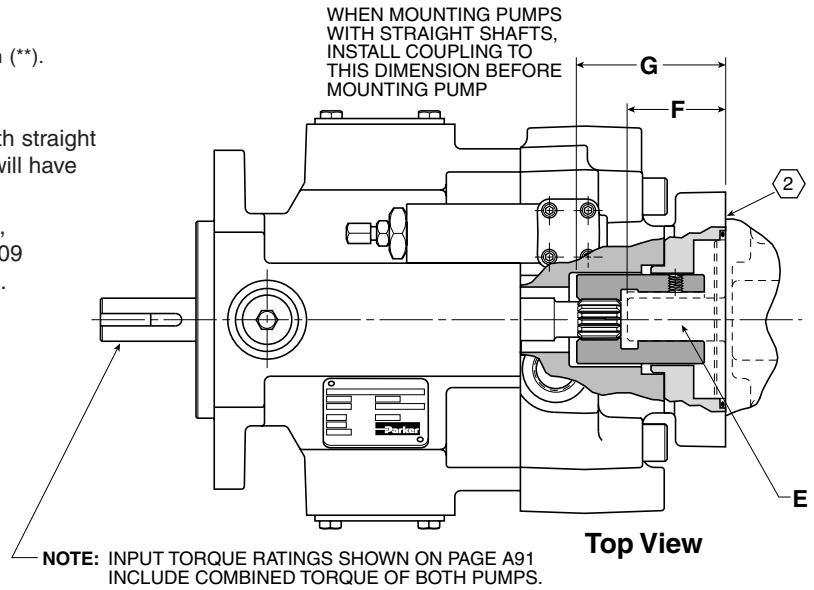

Dimensions – Thru Shaft Options

VARIATION	A	B	C	D	E	F	G
6A4	263.91 (10.39)	82.58/82.60 (3.251/3.252)	53.19 (2.09)	3/8-16UNC-2B	9 Tooth 16/32 Pitch	31.75 (1.25)	N/A
6A5	263.91 (10.39)	82.58/82.60 (3.251/3.252)	53.19 (2.09)	3/8-16UNC-2B	11 Tooth 16/32 Pitch	31.75 (1.25)	N/A
6B3	277.88 (10.94)	101.63/101.65 (4.001/4.002)	73.03 (2.88)	1/2-13UNC-2B	13 Tooth 16/32 Pitch	41.15 (1.62)	N/A
6B4	277.88 (10.94)	101.63/101.65 (4.001/4.002)	73.03 (2.88)	1/2-13UNC-2B	15 Tooth 16/32 Pitch	45.97 (1.81)	N/A
9A4	263.91 (10.39)	82.58/82.60 (3.251/3.252)	53.19 (2.09)	M10 X 1.50	9 Tooth 16/32 Pitch	31.75 (1.25)	N/A
9A5	263.91 (10.39)	82.58/82.60 (3.251/3.252)	53.19 (2.09)	M10 X 1.50	11 Tooth 16/32 Pitch	31.75 (1.25)	N/A
9B3	277.88 (10.94)	101.63/101.65 (4.001/4.002)	73.03 (2.88)	M12 X 1.75	13 Tooth 16/32 Pitch	41.15 (1.62)	N/A
9B4	277.88 (10.94)	101.63/101.65 (4.001/4.002)	73.03 (2.88)	M12 X 1.75	15 Tooth 16/32 Pitch	45.97 (1.81)	N/A

Remote Compensator Control Pump Dimensions

* Inch equivalents for millimeter dimensions are shown in (**).

NOTES:

1. Righthand (CW) rotation rear ported pump shown. Lefthand (CCW) pumps will have inlet and outlet ports reversed.
2. When controlling pump compensator pressure with remote relief valve, size relief valve to pass 1.89 LPM (.5 GPM).
3. Remote compensator shown on rear ported pump. Also available on side ported or thru-shaft option pumps.

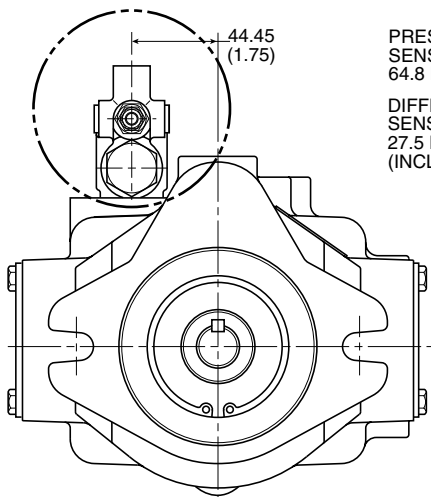
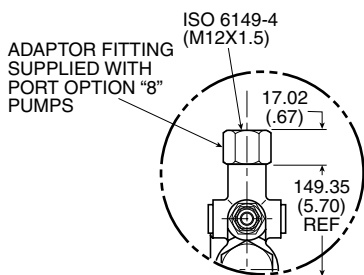
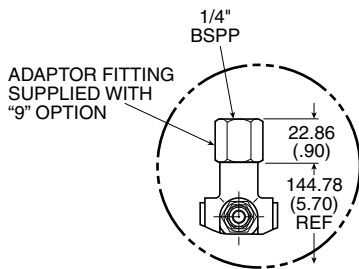

Front View

PRESSURE COMPENSATOR ADJUSTMENT
 SENSITIVITY: APPROXIMATELY
 64.8 BAR (940 PSI) PER TURN

DIFFERENTIAL PRESSURE ADJUSTMENT
 SENSITIVITY: APPROXIMATELY
 27.5 BAR (400 PSI) PER TURN
 (INCLUDED ON "A" CONTROL OPTION)

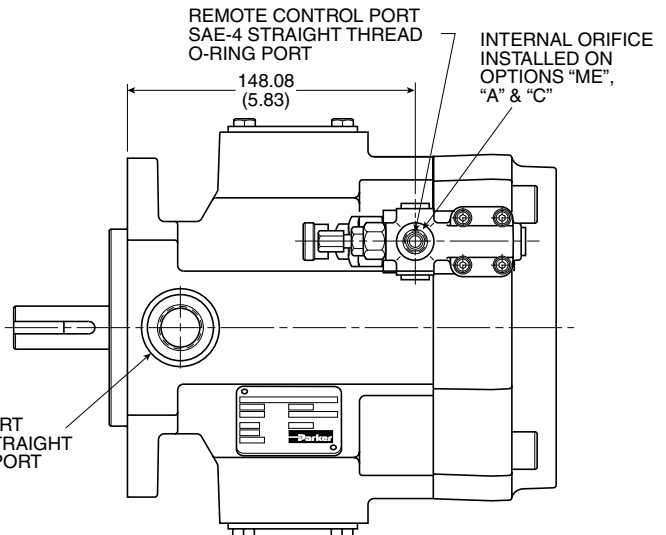

Top View

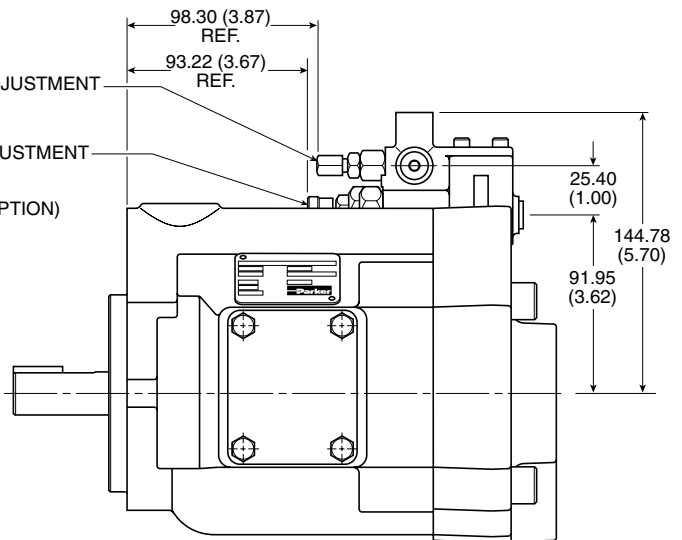

Side View

Power (Torque) Control Pump Dimensions

* Inch equivalents for millimeter dimensions are shown in (**).

NOTES:

1. Righthand (CW) ported pump shown.
2. Power (Torque) control shown with rear ported pump.
 Also available on side ported and thru-shaft pumps.
3. Power torque control does not change with rotation.

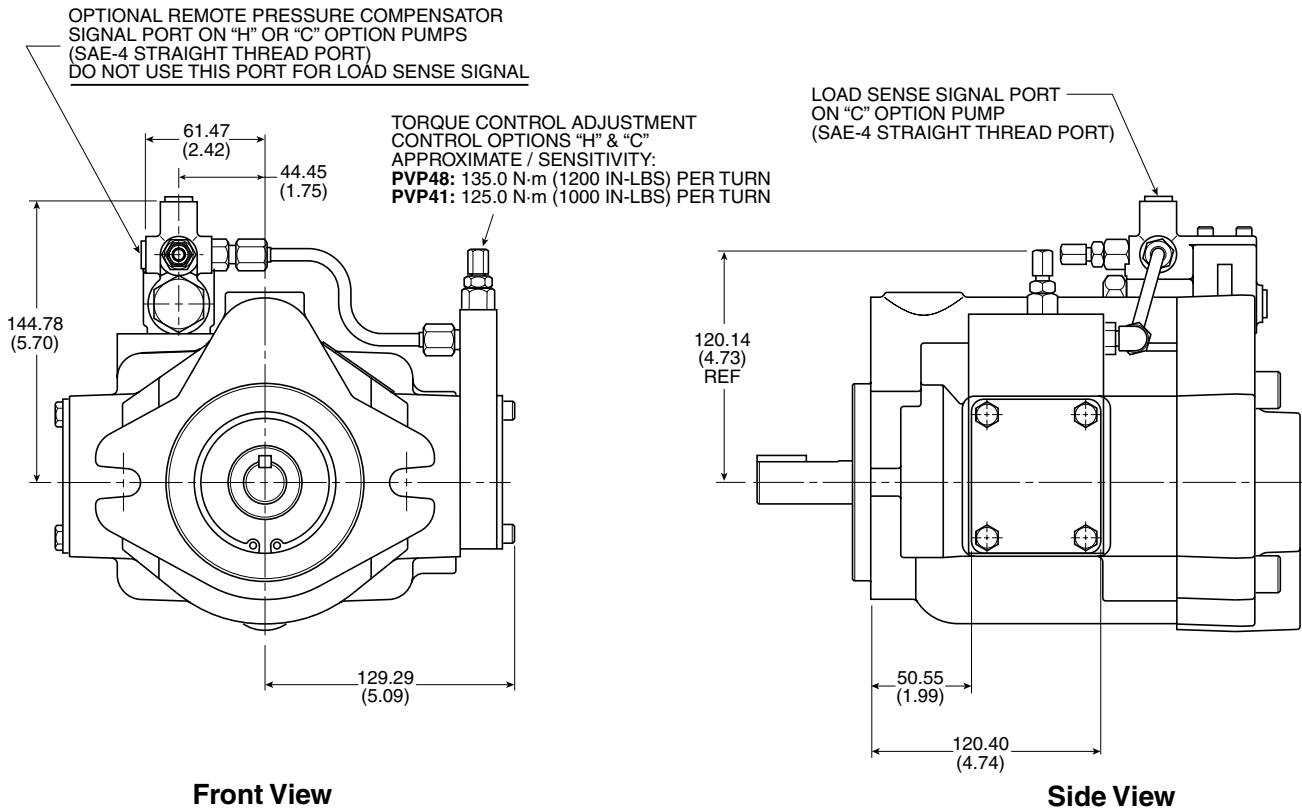

Use of a Relief Valve

The use of a relief valve, while not mandatory is recommended in the main circuit to suppress hydraulic shock loads and adds additional system protection.

Fluid Recommendations

Premium quality hydraulic oil with a viscosity range between 150-250 SSU (30-50 cst.) at 38°C (100°F). Normal operating viscosity range between 80-1000 SSU (17-180 cst.). Maximum start-up viscosity is 4000 SSU (1000 cst.).

NOTE: Consult Parker when exceeding 71°C (160°F) Inlet Fluid Temperatures. Oil should have maximum anti-wear properties, rust and oxidation treatment.

Filtration

For maximum pump and system component life, the system should be protected from contamination at a level not to exceed 125 particles greater than 10 microns per milliliter of fluid. (SAE Class 4/ISO 16/13.) Due to the nature of variable displacement pumps, variations in pump inlet conditions, fluid acceleration losses, system aeration, and duty cycle we do not recommend suction line filters. We do recommend the use of a properly sized, in-tank, suction strainer. Contact your Parker representative for assistance.

Start-Up

On initial start-up, the case should be filled with oil, pressure adjustments should be reduced and the circuit should be open to permit priming.

Inlet Conditions

Not to exceed .17 bar (5 In. Hg.) Vacuum at 1800 RPM on petroleum base fluids. See recommended speed spectrum for specific inlet conditions.

Shaft Rotation and Line Up

Pump and motor shaft alignment must be within .010 TIR maximum, using a standard floating coupling. Please follow coupling manufacturer's recommended installation instructions to prevent end thrust on pump shaft. Turn pump to assure freedom of rotation. Pump and motor must be on a rigid base.

The coupling should be sized to absorb the peak horsepower developed.

**Installation and Mounting**

When mounting a PVP Series Pump, the “case drain” must be on top of the pump. The “case drain” should be a separate line unrestricted to the reservoir and extend below the oil level as far from the inlet line as possible. The “case drain” line must not exceed **.7 bar (10 PSI)** back pressure. Suggested maximum line length is 10 feet.

Special Installations

Consult your Parker representative for any application requiring the following:

Pressure above rated, drive speed above maximum, indirect drive, fluid other than petroleum oil, oil temperature above 71°C (160°F).

Inlet Pressure

Not to exceed 1.72 bar (25 PSI).